

Utilisation Procedures

For all commercial harvesting and haulage managed by VicForests

November 2013 (Version 7.0)



Document Information



Revision History

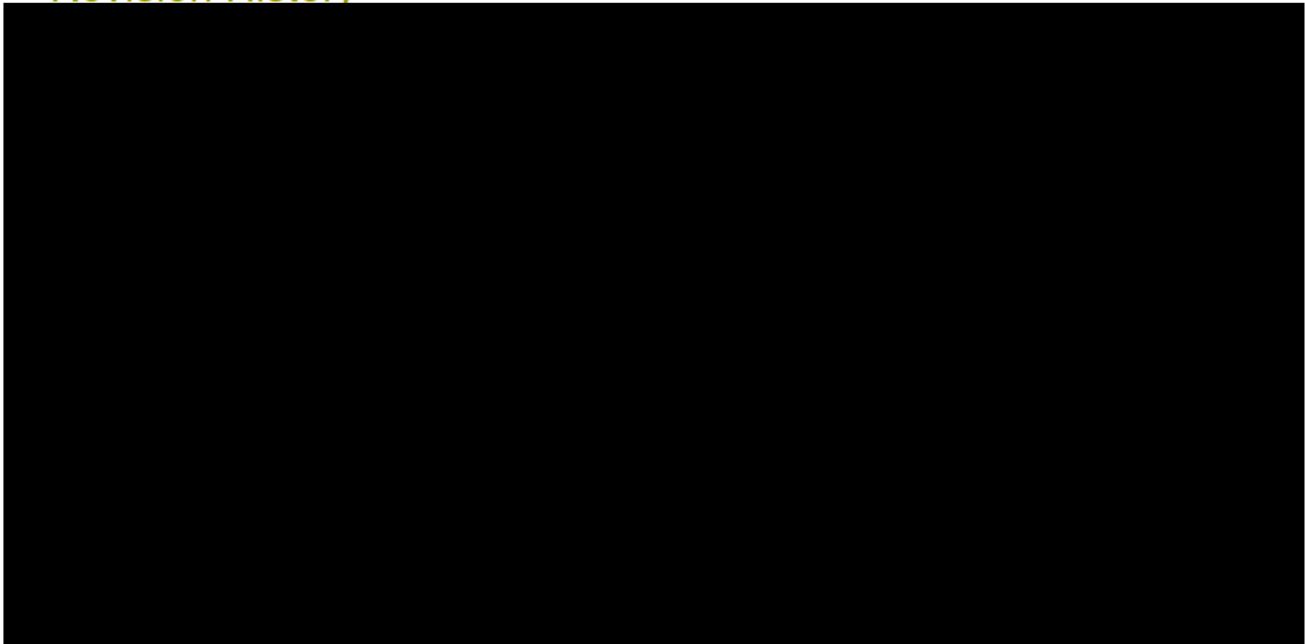

Reviewers

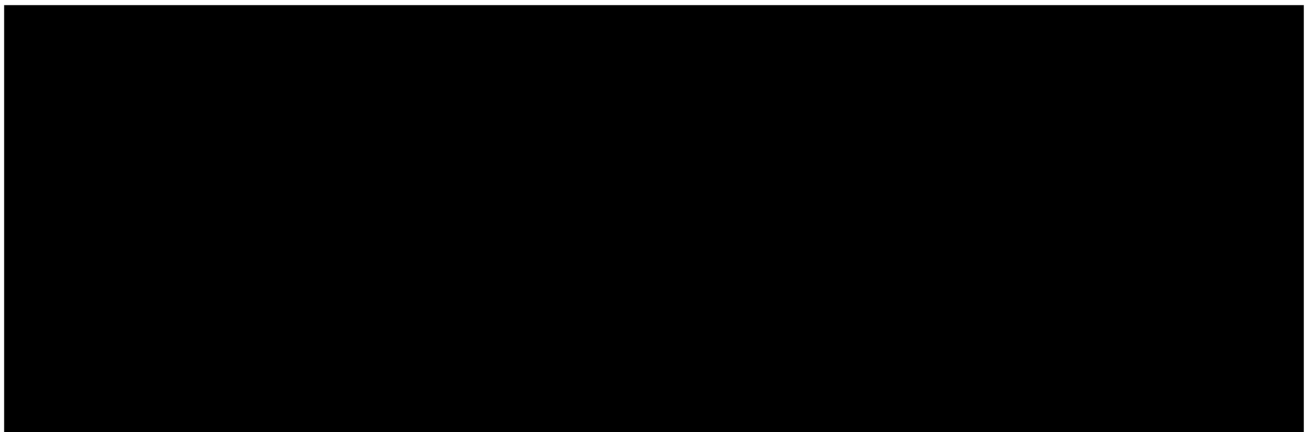

Approval

Approver



Signature:

Position



Date

31/01/2014

Contents

1.	DICTIONARY	7
2.	INTRODUCTION	14
2.1	Purpose of Procedures	14
2.2	Application of Procedures	14
2.3	Variation of Procedures	14
2.4	Failure to comply with Procedures	14
2.5	Cost of Compliance	14
2.6	Review and Alteration of Procedures	14
3.	HARVESTING OBLIGATIONS	15
3.1	Contractor's Obligations of Parties	15
3.2	Logging Team Leader's Obligations	15
3.3	Log Storage Site Operator's Obligations	16
3.4	VicForests Representative's Obligations	17
3.5	Licensed Timber Harvesting Operator's Obligations	17
3.6	Other Persons Engaged in Commercial Harvesting Obligations	17
4.	COUPE BOUNDARIES	18
4.1	Marking A Coupe	18
4.2	Construction of Boundary Trails	18
4.3	Location of Boundary Trails	18
4.4	Converting a boundary trail to a fire trail	19
4.5	Drainage and rehabilitation	19
4.6	Rehabilitation of control tracks created in burn escapes	19
5.	EXCLUDED AREAS	20
5.1	Activities in excluded areas	20
5.2	Activities in Filter Strips	20
6.	HARVESTING REQUIREMENTS	20
6.1	Retained Trees	20
6.2	Trees to be felled	21
6.3	Stump Heights	21
6.4	Protection of Roads, Structures and Works	21
6.5	Coupe Utilisation Requirements	21
7.	SAFETY	22
7.1	Safety Standards	22
7.2	Inductions	22
7.3	Reporting Incidents and Investigation	22
7.4	Tree felling	23

7.5	Plant, equipment and machinery standards	23
7.6	Minors (Children) at Worksites	23
7.7	Management of visiting groups	24
8.	THINNING REQUIREMENTS	24
8.1	Trees to be removed	24
8.2	Trees to be retained	24
8.3	Thinning method	24
8.4	Damage	25
8.5	Rehabilitation of Extraction Tracks	25
9.	EXTRACTION (SNIG AND FORWARDING) TRACKS WITHIN COUPES	25
9.1	Location of Extraction Tracks	25
9.2	Blading-off	26
9.3	Drainage and Rehabilitation	26
9.4	Snigging on roads	26
9.5	Stream Crossings	26
10.	LOADING BAYS	27
10.1	Loading Bays (Thinning)	27
11.	LANDINGS	27
11.1	Location of Landings	27
11.2	Construction and Maintenance of Landings	27
11.3	Landing Operation	28
11.4	Loading	28
11.5	Bark Disposal	30
11.6	Drainage	30
11.7	Rehabilitation	30
12.	ROAD CONSTRUCTION AND MAINTENANCE	31
12.1	Responsibility for Constructing, Upgrading and Maintaining roads	31
12.2	Location, Design and Period of Construction	31
12.3	Blasting	31
12.4	Grade	32
12.5	Clearing	32
12.6	Earth-Works	32
12.7	Drainage	32
12.7.1	Drainage Principles	32
12.7.2	Time of Construction	33
12.7.3	Construction of Silt Traps	33
12.7.4	Construction of Table Drains	33
12.7.5	Construction of Cross-Drains	33
12.8	Maintenance	34
12.9	Stream and Drainage Line Crossings	34
12.10	Bridges	34
12.11	Crossings	35

12.12	Culverts	35
12.13	Temporary Road Closure	35
12.14	Permanent Road Closure	36
12.15	Traffic Management	36
12.16	Removal and Rehabilitation of Bridges, Crossings and Culverts	36
12.17	Moving Heavy Machinery on Forest Roads	36
13.	QUARRIES, BORROW PITS AND FILL DISPOSAL AREAS	37
14.	PREPARATION AND MEASUREMENT OF LOGS	37
14.1	Work zones	37
14.2	Log preparation	37
14.3	Determining if timber is not merchantable	38
14.4	Marking	38
14.5	Measuring Logs by Volume	38
14.6	Measuring Logs by Weight	39
14.7	Recording Timber Resource – Electronic Dockets (Primary System)	40
14.8	Recording Timber Resource – Log Dockets (Secondary System)	41
14.9	Recording Timber Resource – Load Dispatch Records (Secondary System)	43
14.10	Recording Timber Resource – Log Tags	43
14.11	Synchronisation of Handheld Units	44
15.	GRADING LOGS	44
15.1	Contractor Grading	44
15.2	Contractor Hammers	44
16.	USING THE HARDWOOD LOG GRADING CARD	44
17.	GRADING INTERPRETATIONS	45
17.1	Short Logs	45
17.2	Multigrading	45
17.3	Using pipe and defect quarter allowances	45
17.4	Gum Veins	46
17.5	Sloping Grain Interpretation	46
17.6	Stem Defect	47
17.7	Mechanical damage	47
17.8	Stain	47
17.9	Sweep	48
17.10	Ambrosia	48
17.11	Black Fleck	48
17.12	Long Butting	48
18.	OFF SPECIFICATION TIMBER	49
18.1	General Disputes	49
18.2	Machine Damage	49
18.3	Measurement Half Logs	50
18.4	Local Grading Rules	50

19.	CARTING LOGS	51
19.1	General Obligations of Driver	51
19.2	Authorised Hours	52
19.3	Suspension of Cartage	52
19.4	Checking Loads	52
20.	LOG STORAGE SITES	53
20.1	Log Storage Site Plans	53
20.2	Log Storage Site Operators	53
20.3	Transit Log Storage Sites	53
21.	WEATHER RESTRICTIONS	53
22.	FIRE PROTECTION	54
22.1	Access for Fire Suppression	54
22.2	Fire Fighting	54
22.3	Fire Fighting Equipment	54
22.4	Fire Precautions	55
23.	STORING AND USING FUEL AND SERVICING MACHINERY	55
23.1	Location	55
23.2	Precautions	55
23.3	Spills	56
23.4	Disposing of waste	56
24.	CAMP SITES, WASTE DISPOSAL AND FOREST HYGIENE	56
24.1	Camp sites	56
24.2	Disposing of Waste	57
24.3	Water Points	57
24.4	Forest Hygiene	57
24.5	Selecting a Field Washdown Site for Machinery	57
24.6	General Washdown Procedure for Machinery	58
25.	COMPLETION OF COMMERCIAL HARVESTING	58
25.1	Restoration of roads, structures and works	58
25.2	Coupe Completion	58
26.	CONTRACTOR PERFORMANCE	59
26.1	Assessment of Contractor Performance	59
26.2	Monthly Plans	60

Schedules

Schedule 1	Recommended Maximum Distance in Metres Between Cross Drains for Rehabilitation of Extraction Tracks and Boundary Tracks
Schedule 2	Design Standard Guidelines for Roads
Schedule 3	Maximum Clearing Widths (m) Required for Typical Road Construction
Schedule 4	Maximum Distances in Metres Between Road Run-Offs, Cross Drains and Culverts on Roads
Schedule 5	Minimum Number of Habitat Trees
Schedule 6	Guide to Selecting Seed Trees
Schedule 7	Cording And Matting Prescriptions
Schedule 8	Coupe Marking Standard Procedures
Schedule 9	Sawlog Timber Specifications
Schedule 10	Pulplog Timber Specifications
Schedule 11	Species Codes
Schedule 12	Grade Codes
Schedule 13	Hardwood Log Grading Card

1. DICTIONARY

(a) In these Procedures, unless the context requires otherwise:

<i>Term</i>	<i>Definition</i>
ABE	means class A, B and E fires. Fires that involve wood, cloth, paper, most plastics, rubber & textiles (A), fires that involve flammable and combustible liquids i.e. petrol, oil, grease & paints (B) and fires that involve electrical energised equipment (C);
Accredited Log Grader	means a log grader accredited by DEPI or VicForests;
Allocation Order	Means an order made in accordance with the <i>Sustainable Forest (Timber) Act 2004</i> .
Authorised DEPI Officer	means a DEPI person appointed as an authorised officer under the <i>Conservation Forests and Lands Act 1987</i> for legislation relevant to commercial harvesting on State forests;

Blading off	means the use of a machine to sweep drifts of loose mud, slush, vegetation or soil from the surface of a road, or coupe infrastructure (landings etc); (whether it be using the front of the blade or back blading)
Boundary trail	means a trail established inside the boundary of a coupe by machine removing or flattening vegetation to define the coupe boundary location. The trail is not necessarily cleared to mineral earth;
Buffer (strip)	means a protective margin of vegetation excluded from any harvesting activity abutting a waterway or an area of rainforest or other special area, which protects it from potentially detrimental disturbances in the surrounding forest. Buffer width is defined as horizontal distance from which various operations are excluded;
Bunding	A construction around potential spillage areas to reduce the risk of environmental contamination. It is important these structures can retain the volume of any potential spillage and may be constructed of earth or plastic;
Cable Logging	means a logging operation that involves retrieval of logs using a yarder and skyline cable that extend down into the forest to where trees are being harvested.
Code	means the Code of Practice for Timber Production 2007 adopted under the provisions of Part 5 of the <i>Conservation, Forests and Lands Act 1987</i> ;
Commercial Harvesting	includes Timber Harvesting (see definition) as defined in the <i>Sustainable Forests (Timber) Act 2004</i> and to the extent that they are not included in that term, the following activities: <ul style="list-style-type: none"> • collecting seed for silvicultural purposes; and • constructing, improving and maintaining roads (including rock quarries, borrow pits and fill disposal areas); and • transporting machinery to and from a coupe; and • operating machinery within a coupe; and • rehabilitating a coupe; and • operating a Log Storage Site, within Victorian State forest; <p><i>[Note that the definition of “commercial harvesting” is different from the definition of “timber harvesting”]</i></p>
Construction induction	means training approved by Worksafe Victoria and provided by a registered training organisation for the purposes of the OH&S Regulations 2007 construction part;
Contractor	means a person or business engaged in Commercial Harvesting who performs services for VicForests under a contractual agreement;
Cording	means log material, eucalypt and non-eucalypt, with a diameter greater than 15cm that is placed in a corduroy fashion on landings and snig tracks to distribute machine loading over a larger area thus reducing soil compaction. It also separates machine tracks / wheels from the soil surface reducing the capacity for rutting to occur;
Coupe	means a coupe defined in accordance with the Code, including any excluded area within the boundaries of the coupe, and any access road which links a coupe to an existing road;
Coupe-access road	means a road that links permanent roads to in-coupe roads, located outside of the harvesting area. VicForests is responsible for arranging the construction and maintenance of coupe-access roads;

Coupe diary	<p>means a series of written and dated journal entries maintained in duplicate by the logging contractor and VicForests representative and makes up part of the forest coupe plan. The coupe diary should record events and decisions that have occurred during the life of the harvesting operation such as:</p> <ul style="list-style-type: none"> • variations and amendments to the Utilisation Procedures (if approved by a VicForests representative); • amendments to the Forest Coupe Plan (if approved by a VicForests representative); • any instructions regarding harvesting the coupe (given by a VicForests representative); • record of breaches of the Coupe Plan, Code of Practices for Timber Production or the Utilisation Procedures; • amendments to the list of Timber Harvesting Operator Licence holders working on the coupe; • documentation of OH&S issues (those found subsequent to the pre-harvest hazard identification inspection); • agreements on the nature and extent of additional works; • issues raised by the Contractor for VicForests consideration; and • new special values identified in the field that were not described in the Forest Coupe Plan eg. Cultural heritage site; • any other issues relevant to specific Operations and Coupe.
Cross draining (of roads)	<p>means placing of interception drains provided across the longitudinal direction of the road to divert water from the road surface;</p>
Crowned (in relation to roads)	<p>means the formation of a road surface by a grader or dozer to a convex-shape from which water will freely drain to both sides away from the middle;</p>
Culling	<p>means felling, pushing or poisoning of non-merchantable trees;</p>
Customer	<p>means a person or body corporate that has entered into an agreement to purchase timber from VicForests. It includes persons or body corporate:</p> <ul style="list-style-type: none"> • holding a Licence relating to forest produce issued by the Secretary under section 52 or 21 of the <i>Forests Act</i> 1958, the administration of which has been transferred to VicForests; and/or • entering into a timber sale agreement governing the sale and supply of timber by VicForests; and/or • awarded a timber lot through sealed bid or on line auctions that is subject to terms and conditions for timber sales • holding an agreement with respect to the supply of pulp wood issued under the <i>Forests (Wood Pulp Agreement) Act</i> 1996;
Damage	<p>(i) in relation to standing timber, means:</p> <ul style="list-style-type: none"> • any obvious wound to the main bole where splitting or removal of bark is significant; or • any wound where fibrous inner bark has been severely torn, tufted or bruised; or • any cut, gash or puncture; or • any damage to more than 30% of the original crown; and <p>(ii) in relation to felled timber or any other forest produce, means any physical damage to the timber or other forest produce which may reduce its market value;</p>
DBHOB (Diameter Breast Height Over Bark)	<p>means the diameter of a tree measured over the bark, at 1.3 metres above ground level and, if the tree is on a slope, measured on the up-hill side of the tree;</p>

Delivery Site	means a site owned or occupied by a Customer to which Timber is delivered or a Log Storage Site;
Drainage line	means depressions that have visible evidence of periodically flowing water (including obvious sedimentation or other clear evidence of overland flow) that feed into temporary or permanent streams. A defined channel may or may not be present. Visible water flow would be expected after storm events or briefly in the wettest times of the year. Distinctive riparian vegetation is not likely to be present. Artificial drainage lines that do not discharge directly into waterways are not considered within the above definition.
DEPI	means the Secretary to the Department of Environment and Primary Industries or delegate;
Excluded area	means an area identified on a Forest Coupe Plan as being excluded from harvesting;
Extraction track	includes snig track and forwarding track within the meaning of the Code;
Felling	includes pushing and manual or mechanical cutting;
Filter strip	means a strip of vegetated ground adjacent to a waterway (with merchantable overstorey removed) retained to minimise soil compaction and erosion. Trees may be felled from within a filter strip subject to certain conditions; however machinery entry is generally not permitted;
Fire trail	means a mineral earth firebreak;
Forest Coupe Plan	means a Forest Coupe Plan as defined by the Code;
In-coupe road	means a timber-extraction road constructed specifically for use during the harvesting operation and closed at the completion of harvesting. It is located completely within the harvest area and constructed and maintained by the Contractor;
Landing	a place where trees or parts of trees are snigged for sorting and processing and loaded for transport from the forest. Note: Storage areas of cross-cut, forwarded logs placed by excavator where there has been no significant soil disturbance associated with landing establishment, and in which no further processing takes place, are not regarded as landings. Conversion sites at which small amounts of produce are processed and which do not involve earthworks or clearing are also not regarded as landings;
Licensed Timber Harvesting Operator	means a person holding a current valid Timber Harvesting Operator's Licence (THOL);
Loader	means a person who places or restrains the load on a vehicle;
Loading Bay (thinning)	means a stockpile of logs that was created without machine processing and significant soil disturbance that is ready for loading onto trucks;
Loading Manager	means a person who manages premises where five or more heavy vehicles are loaded or unloaded each day, or supervises or controls a loader or unloader. Usually the Logging Team Leader or Log Storage Site Operator;
Log Storage Site	means a delivery site operated by or on behalf of VicForests where logs are delivered and stored prior to final delivery to a customer;

Log Storage Site Operator	means a Log Storage Site Operator appointed under paragraph 3.1(a);
Log Storage Site Plan	means a plan prepared by VicForests for the establishment and / or operation of a Log Storage Site;
Logging Team Leader	means the principal licensee or harvesting contractor, or a person appointed by the principal licensee or harvesting contractor, responsible for supervising and controlling a timber harvesting operation in the forest;
Matting	is the smaller head material (branches), bark or other vegetation that is used to cover cording on snig tracks and landings;
Permanent road	means a road permanently required for the continuing management of the forest;
Permanent stream	means rivers and streams that flow throughout the year. Permanent streams may stop flowing or dry out in extremely dry years. Permanent streams will support distinctive riparian vegetation indicative of extended periods of saturation and distinguishable from vegetation communities in surrounding areas. Permanent streams have a well-defined incised permanent channel;
Pest-plant	means any State prohibited weed, regionally prohibited weed, regionally controlled weed or restricted weed, as defined in the <i>Catchment and Land Protection Act 1994</i> ;
Pool	means an area of still water of at least 4 metres in diameter within or adjacent to the main channel of a permanent or temporary stream. A pool may dry out in extremely dry years;
Residual Log	means a log below the standard of a sawlog but does not include domestic firewood;
Retained tree	means trees retained on a coupe during a harvesting operation because they are un-merchantable, are to serve as seed trees or wildlife habitat trees, or have been selected to grow on after thinning;
Road Class – 5C	means an all weather single lane two-way unsealed formed road usually lightly gravelled. It caters for low travel speed and a full range of vehicles;
Road Class – 5D	means a short term, temporary or feeder road used to access individual timber harvesting coupes. It caters for low travel speed and a range of vehicles in dry weather and may be seasonally closed. Substantially, a single lane two-way generally dry-weather, formed (natural materials) track or road;
Road Class – 5E	means a single lane two-way earth tracks (unformed) at or near the natural surface level and predominantly not conforming to any geometric design standard. It caters for very low travel speed and may be seasonally closed;
Road pavement	means the portion of a road, excluding shoulders, placed above the design sub-grade for the support of, and to form a running surface for, vehicles;
Sawlog	means a sawlog as determined by application of the Hardwood Log Grading card and may include B, C, D and E grade logs;
Saturation zone	means associated with waterways, the area where the soil is muddy or permeated with water attributable to the water body. The zone ends where moisture is no longer visibly present in the soil. This zone is often delineated by riparian vegetation;
Secretary	means the Secretary to the Department of Environment and Primary

Industries;

Seed trees	means trees retained on harvested coupes to provide seed for natural regeneration of that coupe. May also be a Habitat Tree;
Selection systems	means a silvicultural system used for harvesting and regeneration where trees are harvested either singly or in small groups at relatively short intervals (usually 10–20 years) over the rotation. Regeneration is established in the gaps produced and an uneven-aged stand is maintained;
Significant rutting	means rutting to a depth of more than 200 mm below the original ground level over a 15 m section;
Snig track	means the track along which a log is snigged;
Temporary road	means a road or track and any associated bridges, crossings and culverts that does not form part of the permanent road network. A temporary road is mostly constructed for the purpose of accessing a coupe(s) (or part thereof) to undertake timber harvesting operations and associated activities and will be closed and rehabilitated on the completion of timber harvesting operations and associated activities in that coupe(s). A temporary road includes in-coupe roads and coupe-access roads;
Temporary stream	means streams that have a clearly defined continuous channel or streambed and flow during certain seasonal periods of the year, such as following snowmelt, but not throughout the entire year. Temporary streams contain distinctive riparian vegetation, indicative of periods of saturation and distinguishable from vegetation communities in surrounding areas;
Thinning	means the removal of part of a forest stand or crop, with the aim of increasing the growth rate and/or health of retained trees;
Timber	means the timber from the trees or part of trees specified by VicForests as available for harvesting in an Annual Plan or Monthly Plan;
Timber harvesting	<p>as defined in the <i>Sustainable Forests (Timber) Act</i> 2004 means any of the following kinds of activities carried out by VicForests or by any other person or body for the purposes of sale or processing and sale:</p> <ul style="list-style-type: none">• felling or cutting of trees or parts of trees;• taking or removing timber;• delivering timber to a buyer or transporting timber to a place for collection by a buyer or sale to a buyer;• any works, including road works, ancillary to any of the activities referred to above. <p>It does not include:</p> <ul style="list-style-type: none">• those activities when undertaken by or on behalf of the Crown or the DEPI Secretary; or• the collection of firewood for domestic use;
Timber Harvesting Operator's Licence (THOL)	means a Timber Harvesting Operator's Licence issued by the DEPI Secretary under the <i>Sustainable Forests (Timber Harvesting) Regulations</i> 2006. As of 1 July 2006, a Forest Operator's Licence (FOL) was replaced by a Timber Harvesting Operator's Licence (THOL);
Timber resources	means timber from the trees or parts of trees which are specified as available for timber harvesting in an Allocation Order but does not include firewood collected for domestic use;
Timber Sale Agreement	is an agreement between VicForests and its customers for the sale of timber resources;

Transit Log Storage Site	means a Log Storage Site managed by one or more haul contractors for flexibility in managing haul operations. Logs will be accounted for (both harvest and haulage) upon receipt at a scheduled delivery site;
Truck	includes any vehicle and any trailer used in conjunction with a vehicle, used for commercial harvesting;
VicForests	is the State business corporation created under the <i>State Owned Enterprises Act 1992</i> , on 28 October 2003, to undertake the management and sale of timber resources and associated activities, in Victorian State forests;
VicForests Representative	means an employee of VicForests engaged in activities associated with the supervision or monitoring of operations associated with commercial harvesting;
Wetland	means a permanent spring, swampy ground, wetland or other body of standing water. A wetland may dry out seasonally. A wetland will support distinctive riparian vegetation (not including <i>E. camaldulensis</i>), indicative of extended periods of saturation and distinguishable from vegetation communities in surrounding areas;
Yarding	means the act of conveying logs to a landing, using a cable harvesting system.

- (b) A reference to any legislation or legislative provision includes any statutory modification or re-enactment of, or legislative provision substituted for and any subordinate legislation issued under, that legislation or legislative provision;
- (c) the singular includes the plural and vice versa;
- (d) a reference to a clause, sub-clause, paragraph or schedule is to a clause, sub-clause, paragraph or schedule of these Procedures;
- (e) a reference to any document is to that document (and, where applicable, to any of its provisions) as amended, novated, supplemented or replaced from time to time;
- (f) a reference to a person in these Procedures or in any other document or arrangement includes that person's:
 - (i) employees, officers, agents or contractors; and
 - (ii) substitutes, successors and permitted assigns;
- (g) if a word is defined, another part of speech has a corresponding meaning;
- (h) if an example of a thing is given (including a right, obligation or concept) such as by saying it includes something else, the example does not limit the scope of the thing;
- (i) headings are for convenience only and do not affect interpretation;
- (j) a clause looks like this:

1. Introduction
- (k) a sub-clause looks like this:

1.2 An authorised officer may....
- (l) a paragraph looks like this:

(a) An authorised officer may....
- (m) a sub-paragraph looks like this:

(iii) An authorised officer....

2. INTRODUCTION

2.1 Purpose of Procedures

- (a) These Procedures set out environmental and operational requirements which must be followed for all commercial harvesting and haulage managed by VicForests.
- (b) Insofar as these procedures relate to State forest, they are the "Private Sector (Forest Operator) Regional (FMA) Prescriptions" made under the Code.

2.2 Application of Procedures

- (a) Every Contractor and Licensed Timber Harvesting Operator engaged in VicForests commercial harvesting must comply with these Procedures:
 - (i) where it is reasonably practical to do so; and
 - (ii) without compromising their requirement to work safely at all times, in line with their obligations under the *Occupational Health and Safety Act 2004 (VIC)* as well as relevant regulations, Codes of Practice and Australian Standards; and
 - (iii) without compromising their requirement to comply with all relevant legislation.
- (b) Where a Contractor cannot comply with these procedures in accordance with (a), the supervising VicForests representative must be informed immediately.

2.3 Variation of Procedures

- (a) A VicForests representative may vary these Procedures, if the provision is consistent with the Code and Management Procedures, by noting the change in a Forest Coupe Plan or Log Storage Site Plan. Where the provision is inconsistent, written approval from DEPI is required to vary these procedures.
- (b) After commercial harvesting commences, a Forest Coupe Plan or Log Storage Site Plan may only be varied in writing in the coupe diary or noted on the Forest Coupe Plan or Log Storage Site Plan and signed and dated by a VicForests representative.

2.4 Failure to comply with Procedures

- (a) If a Contractor or their employee fails to comply with any provision of these Procedures, depending on the circumstances there may be a breach of a contract between the Contractor and VicForests.
- (b) A VicForests representative will monitor compliance with these Procedures by each Contractor and Licensed Timber Harvesting Operator.

2.5 Cost of Compliance

- (a) The cost of complying with these Procedures must be borne by the Contractor or Licensed Timber Harvesting Operator, as the case requires, except where these Procedures expressly require VicForests to bear the cost.

2.6 Review and Alteration of Procedures

These Procedures:

- (a) may be reviewed and altered at any time by VicForests; and
- (b) will be reviewed periodically to ensure consistency with:
 - (i) relevant legislation;
 - (ii) the Code of Practice for Timber Production;
 - (iii) the DEPI Management Procedures.

3. HARVESTING OBLIGATIONS

3.1 Contractor's Obligations of Parties

A Contractor:

- (a) must designate a person who is a Licensed Timber Harvesting Operator to be:
 - (i) the Logging Team Leader for a coupe; or
 - (ii) the Log Storage Site Operator for a Log Storage Site, before commencing any commercial harvesting in that coupe or commencing to operate that Log Storage Site, as the case requires; and
- (b) will be held responsible, under these Procedures for any act or omission by a person acting on the Contractor's behalf; and
- (c) must not give a direction to any such person which is contrary to:
 - (i) any provision of these Procedures; or
 - (ii) any direction given by a VicForests representative; or
 - (iii) any relevant legislation; or
 - (iv) any lawful direction given by an Authorised DEPI Officer.
- (d) must not remove commercial quantities of firewood produce from State forest without a VicForests' Sales Agreement; and
- (e) must gain written consent from VicForests for photos taken of active coupes or operations for public distribution or other use.

3.2 Logging Team Leader's Obligations

A Logging Team Leader:

- (a) must hold a current valid Timber Harvesting Operator's Licence and any other necessary relevant accreditation or qualification for the work that person does; and
- (b) must sign the Harvesting Commencement Declaration set out on the Forest Coupe Plan prior to the commencement of harvesting; and
- (c) must ensure that every person working on the coupe under the provisions of a specific Forest Coupe Plan:
 - (i) who is required to hold a current valid Timber Harvesting Operator's Licence or any other relevant accreditation or qualification for the work that person does, holds that Licence, accreditation or qualification, as the case requires; and
 - (ii) complies in all respects with relevant legislation, the Code, these Procedures, and the relevant Forest Coupe Plan; and
 - (iii) complies with every relevant occupational health and safety requirement; and
- (d) must be responsible for ensuring all associated, non-licensed persons (eg float operators) comply, in all respects, with the Code, Procedures, directions of a VicForests representative and the Forest Coupe Plan; and
- (e) must allow a VicForests representative to inspect the coupe whenever a VicForests representative so requires; and
- (f) must receive and disseminate to each relevant person working on the coupe, any direction from a VicForests representative about commercial harvesting on the coupe; and
- (g) subject to paragraph (j), must be present at the coupe for most of the time which work is done at the coupe; and

- (h) must ensure that harvesting operations at the coupe are properly completed in accordance with clause 25; and
- (i) must comply with all lawful directions of a VicForests representative and Authorised DEPI Officer; and
- (j) must appoint a deputy, to act in place of the Logging Team Leader when the Logging Team Leader is absent from the coupe; and
- (k) must ensure that a VicForests representative is notified of the name of any deputy appointed under paragraph (j) and note the name of the deputy in the coupe diary; and
- (l) must advise a VicForests representative of any breach of these Procedures by any person working on a coupe under the provisions of a specific Forest Coupe Plan; and
- (m) must record events and decisions that have occurred during the life of the harvesting operation in the coupe diary; and
- (n) must, as loading manager, take all reasonable steps to ensure that loading and unloading of vehicles will not cause, or contribute to causing, a truck driver to drive while impaired by fatigue; or drive while in breach of his or her work/rest hours.
- (o) must ensure that any person present at the coupe is provided with an appropriate induction in accordance with Section 7.

3.3 Log Storage Site Operator's Obligations

A Log Storage Site Operator:

- (a) must hold a current valid Timber Harvesting Operator's Licence and any other relevant accreditation or qualification for the work that person does; and
- (b) must execute the Declaration of Receipt of the Log Storage Site Plan, set out on the Log Storage Site Plan for the relevant Log Storage Site, before operating in that site; and
- (c) must ensure that every person working in the Log Storage Site under the provisions of a specific Log Storage Site Plan:
 - (i) who is required to hold a valid Timber Harvesting Operator's Licence or any other accreditation or qualification for the work that person does, holds that Licence, accreditation or qualification, as the case requires; and
 - (ii) complies in all respects with relevant legislation, the Code, these Procedures, and the relevant Log Storage Site Plan; and
 - (iii) complies with every relevant occupational health and safety requirement; and
- (d) must allow a VicForests representative to inspect the Log Storage Site whenever a VicForests representative so requires; and
- (e) must receive and disseminate to each relevant person working on the Log Storage Site, any direction from a VicForests representative about managing the Log Storage Site; and
- (f) subject to paragraph (h), must be present at the Log Storage Site for most of the time during which work is done at the Log Storage Site; and
- (g) must comply with all lawful directions of a VicForests representative and Authorised DEPI Officer; and
- (h) must appoint a deputy, to act in place of the Log Storage Site Operator when the Log Storage Site Operator is absent from the Log Storage Site; and
- (i) must ensure that a VicForests representative is notified of the name of any deputy appointed under paragraph (h) and note the name of the deputy in the coupe diary; and
- (j) must advise a VicForests representative of any breach of these Procedures by any person working on a Log Storage Site under the provisions of a specific Log Storage Site Plan; and

- (k) must, as loading manager, take all reasonable steps to ensure that loading and unloading of vehicles will not cause, or contribute to causing, a truck driver to drive while impaired by fatigue; or drive while in breach of his or her work/rest hours.

3.4 VicForests Representative's Obligations

- (a) A VicForests representative will advise the Logging Team Leader or the Log Storage Site Operator, as the case requires, as soon as possible when:
- (i) any person working at the coupe or Log Storage Site:
 - is allocated any indicator points; or
 - is suspended because of accumulated indicator points;
 - (ii) the VicForests representative reasonably suspects that a person working on the coupe or Log Storage Site:
 - has committed an offence against the *Forests Act 1958*, the *Sustainable Forests (Timber) Act 2004*, the *Conservation, Forests and Lands Act 1987*, the *Fire Protection Regulations 1992*, or any other legislative requirement; or
 - is in breach of the requirements of these Procedures, the Forest Coupe Plan, VicForests' contract or the Log Storage Site Plan.
 - (iii) a non-compliance has been detected during coupe monitoring and actions have been recorded for the Contractor to address.
 - (iv) the VicForests representative lodges a Corrective Action and Incident Report (CAIR) involving the Contractor.
- (b) A VicForests representative :
- (i) may, whenever the VicForests representative considers it necessary:
 - consult with the Logging Team Leader or contractor in preparing the Forest Coupe Plan, to determine whether any aspects of a draft Forest Coupe Plan might be difficult to implement; and
 - consult with the Logging Team Leader or contractor whenever the Forest Coupe Plan is reviewed; and
 - (ii) must discuss with the Logging Team Leader or contractor:
 - how the Forest Coupe Plan must be implemented; and
 - any special procedures applying to the coupe.
 - (iii) must record events and decisions that have occurred during the life of the harvesting operation in the coupe diary.
- (c) A VicForests representative:
- (i) may, whenever the VicForests representative considers it necessary,
 - consult with the Log Storage Site Operator in preparing the Log Storage Site Plan, to determine whether any aspects of a draft Log Storage Site Plan might be difficult to implement; and
 - consult with the Log Storage Site Operator whenever the Log Storage Site Plan is reviewed; and
 - (ii) must discuss with the Log Storage Site Operator:
 - how the Log Storage Site Plan must be implemented; and
 - any special procedures applying to the Log Storage Site.

3.5 Licensed Timber Harvesting Operator's Obligations

- (a) A person engaged in Timber Harvesting (refer to glossary) must hold a current Timber Harvesting Operator's Licence, which must be endorsed for the work they undertake.

3.6 Other Persons Engaged in Commercial Harvesting Obligations

- (a) Every person engaged in Commercial Harvesting must:

- (i) hold any relevant accreditation or qualification for the work which that person does; and
- (ii) comply in all respects with the Code, these Procedures, the relevant Forest Coupe Plan, the relevant Log Storage Site Plan and any lawful direction of a VicForests representative.

4. COUPE BOUNDARIES

4.1 Marking A Coupe

- (a) Unless otherwise specified in the Forest Coupe Plan, a VicForests representative will mark the coupe on the ground according to Schedule 8.
- (b) Where present, the following features will be recorded in the Forest Coupe Plan and marked on the ground:
 - (i) the boundaries of the coupe (except where those boundaries are obvious from existing natural or man-made features); and
 - (ii) the location of any excluded area; and
 - (iii) the location of buffer and filter strips; and
 - (iv) the location of any planned road; and
 - (v) the location of any planned log landing; and
 - (vi) the location of out-rows for thinning.
- (c) All licensed timber harvesting operators and contractors must comply with the coupe marking.
- (d) A VicForests representative must record variations to the standard procedures listed in Schedule 8 in the Forest Coupe Plan.

4.2 Construction of Boundary Trails

- (a) Where required by the Forest Coupe Plan, a Contractor must:
 - (i) construct a boundary trail along the boundary of any section of the coupe before that section is harvested. A boundary trail must be:
 - at least two metres wide; and
 - cleared of standing vegetation for the period during which operations are conducted on the coupe; and
 - be within, any markings of the coupe made under sub-clause 4.1; and
 - as straight as practicable if the boundary trail is likely to aid fire suppression, and be clear of slash and logging debris wherever possible during harvesting to assist with the construction of the fire trail.
- (b) A boundary trail must be constructed:
 - (i) with due care ensuring the integrity of buffers, filters and other excluded areas are maintained where applicable. This will be achieved by:
 - minimising the amount of debris accumulating outside the boundary trail; and
 - minimising wheel ruts and soil disturbance outside the boundary trail.

4.3 Location of Boundary Trails

Where practicable, boundary trails must be located:

- (a) to avoid sudden changes in gradient; and
- (b) to avoid steep sections of the coupe, particularly if the soil erosion hazard is high. Steep boundary trails are prone to severe erosion and generally incur high maintenance costs.
- (c) in sections of the coupe with a slope of at least 1°. Water will pool on sections that are completely flat.

- (d) on previously cleared land (if any); and
- (e) in vegetation of least fuel load to improve the chance of fire control (if relevant).

4.4 **Converting a boundary trail to a fire trail**

If a Forest Coupe Plan requires a boundary trail to be converted to a fire trail

- (a) the Contractor must, at the cost of VicForests, ensure that:
 - (i) any soil removed during conversion:
 - is spread at the side of the fire trail away from any area which will be burnt and
 - is not formed into windrows; and
 - is not pushed into an excluded area; and
 - (ii) the fire trail is:
 - constructed according to the prescriptions specified in the Forest Coupe Plan;
 - out sloped or cross-drained at intervals no greater than those specified in Schedule 1; and
 - accessible by 4WD vehicles, as determined by a VicForests representative and designated on the Forest Coupe Plan.

4.5 **Drainage and rehabilitation**

A Contractor must ensure that:

- (a) any section of a boundary trail where soil will be disturbed during construction is either out sloped; or provided with cross-drains or inverts at intervals no greater than those specified in Schedule 1; and
- (b) any cross-drain or invert is kept clear of debris for the duration of commercial harvesting in the coupe; and
- (c) any drainage works are within coupe boundary markings and outside excluded areas, unless otherwise recorded on the Forest Coupe Plan.
- (d) Subject to paragraph (e), a Contractor must construct cross-drains:
 - (i) at an angle to the track so as to intercept, slow and direct the flow of water across the track. The angle should be approximately right angles to the water flow, with a slight grade (1-3%) to ensure water is passed from one side of the track to the other; and
 - (ii) where the run-off either filters through undisturbed forest soil or into natural drainage channels. If this is not possible the discharge should be directed onto solid ground, not fill; and
 - (iii) generally at a height above the surface of the track of no less than 0.3 metres on a slope of up to 10° and 0.5 metres on a slope greater than 10°; and
 - (iv) to include an invert, at least 0.2m deep, below the surface of the track;
 - (v) from non-flammable materials (earth and rock) and not from bark.
- (e) A Forest Coupe Plan may include any other specifications or variations concerning drainage and rehabilitation of a boundary trail, which a VicForests representative considers appropriate.

4.6 **Rehabilitation of control tracks created in burn escapes**

- (a) In the event of a controlled coupe burn escape, the Contractor must, at the cost of VicForests, ensure that constructed control lines are drained and rehabilitated in accordance with Schedule 1 unless otherwise authorised by a VicForests representative because:
 - (i) rehabilitation is impracticable, or
 - (ii) the track is required for other purposes, or

- (iii) it would be environmentally damaging to do so.

5. EXCLUDED AREAS

5.1 Activities in excluded areas

- (a) A Contractor must not, in any excluded area:
 - (i) fell any tree or damage any tree ; or
 - (ii) allow any felled tree to fall or slide into the area; or
 - (iii) allow debris to accumulate; or
 - (iv) allow any machine to enter the area,except where that action has been both authorised by a VicForests representative and recorded on the Forest Coupe Plan or coupe diary.
- (b) A Contractor must not remove any tree or part of any tree which falls or slides into an excluded area, unless that action has been both authorised by a VicForests representative and recorded on the coupe diary.
- (c) A Contractor must not locate a cable for a cable harvesting system, or yard any log, through an excluded area, unless the Forest Coupe Plan provides otherwise.

5.2 Activities in Filter Strips

- (a) A Contractor:
 - (i) must not allow machinery to enter a filter strip, except at a location noted on the Forest Coupe Plan; and
 - (ii) must take all reasonable steps to ensure that any tree felled within or outside a filter strip, falls away from the filter strip.
- (b) A Contractor who operates a cable harvesting system:
 - (i) may erect a cable across a filter strip; and
 - (ii) may yard logs across, but not along, a filter strip; and
 - (iii) must protect any crossing of a filter strip with log decking, or by some other means, if a VicForests representative considers that there is a risk that soil at the crossing may be disturbed.

6. HARVESTING REQUIREMENTS

6.1 Retained Trees

- (a) A Contractor must make every effort to protect any tree physically marked or otherwise designated by a VicForests representative to be retained from damage caused by felling or extracting other trees.
- (b) Unless otherwise specified on the Forest Coupe Plan, a Contractor must not allow logging debris to accumulate within 3m of the base of a habitat tree which is physically marked or otherwise designated to be retained.
- (c) In conjunction with a VicForests representative, a Contractor must ensure that:
 - (i) the minimum number of habitat trees as specified in Schedule 5 are retained in the coupe.
- (d) Unless otherwise specified in the Forest Coupe Plan, a Contractor must not:
 - (i) remove or substitute seed trees marked by VicForests, unless approved by a VicForests representative;
 - (ii) select seed trees within a seed tree coupe.
- (e) In East Gippsland and Tambo FMAs, and the North East FMA blocks managed by Gippsland, contractors must ensure that all living trees equal to or greater than 4 metres diameter (or 12.5m circumference) measured at breast height over bark:

- (i) are protected from the direct effects of timber harvesting operations and regeneration burning; and
 - (ii) should not be isolated within the coupe. If possible they should be incorporated into habitat patches.
- (f) Retained trees should not be hazardous trees. Where it is considered that a hazardous tree must be retained then the risk associated with that tree must be managed. This decision must be fully recorded in the coupe diary. All controls must be documented and communicated to anyone who enters that coupe.

6.2 Trees to be felled

Unless otherwise specified in the Forest Coupe Plan, a Contractor must ensure that:

- (a) every tree which, in a VicForests representative's opinion, contains merchantable timber, is felled unless it has been physically marked or otherwise designated by a VicForests representative to be retained; and
- (b) any merchantable timber in a tree is not damaged, before or after it is felled and before it is removed from the coupe; and
- (c) any tree not containing merchantable timber which is designated by a VicForests representative for culling, is culled at VicForests' cost in a safe manner resulting in the least possible soil disturbance.

6.3 Stump Heights

- (a) Subject to paragraph (b) the height of the stump of any tree:
 - (i) with a DBHOB less than 80 cm, which is felled manually, must not exceed 40 cm; and
 - (ii) with a DBHOB greater than 80 cm, which is felled manually, must not exceed one half of the over-bark diameter of the tree; and
 - (iii) which is felled mechanically, must not exceed 40 cm; and
 - (iv) which is felled during thinning must not exceed 15 cm;
 unless agreement with the VicForests representative is reached and the decision is documented in the coupe diary.
- (b) For the purpose of this sub-clause, the height of a stump must be measured from ground level, on the uphill side of the stump.

6.4 Protection of Roads, Structures and Works

Unless otherwise authorised by a VicForests representative and noted on the Forest Coupe Plan, a Contractor must:

- (a) protect every road, structure, work or similar asset from damage throughout commercial harvesting of the coupe; and
- (b) report any such damage which occurs promptly to a VicForests representative; and
- (c) not allow harvesting equipment with tracks or chains to operate on or over any road, structure, work or similar asset maintained by the DEPI Secretary; and
- (d) promptly repair any damage to any road which the DEPI Secretary is required to maintain; and
- (e) immediately and completely remove any fallen tree and debris from any road, structure, work or similar asset and place it at least one metre:
 - (i) beyond the slashable verge of the road; or
 - (ii) away from the structure, work or similar asset; or
 - (iii) at any location designated by a VicForests representative and marked on the Forest Coupe Plan.

6.5 Coupe Utilisation Requirements

- (a) Subject to paragraph (b), a Contractor must ensure that:
 - (i) after harvesting is complete, no part of any merchantable tree (other than a designated retained tree) from which a sawlog of Grade D or better could be cut, remains on the coupe; and
 - (ii) in any clearfall, seed tree, shelterwood or selection coupe, where full residual log utilisation is possible:
 - not more than 10m³ per hectare of merchantable residual log remains on a site with a slope of 15° or less; and
 - not more than 15m³ per hectare of merchantable residual log remains on a site with a slope greater than 15°; and
 - (iii) no sawlog is stockpiled for more than one week in dry conditions (ie conditions that may lead to splitting, checking or other log deterioration), unless the Contractor takes such action as a VicForests representative approves, at the Contractor's cost, to avoid undue deterioration of the merchantable timber.
- (b) A VicForests representative may, from time to time, in response to market forces:
 - (i) alter any requirement set out in paragraph (a); and
 - (ii) record the altered requirement in the Forest Coupe Plan.

7. SAFETY

7.1 Safety Standards

In addition to the Occupational Health and Safety Act, as amended from time to time, there are specific documents which have direct relevance to timber harvesting operations. Contractors must comply with, have a copy of, and be familiar with the:

- (a) Industry Standard: Safety In Forestry Operations (Harvesting and Haulage)
- (b) Fatigue Management Guidelines for the Forestry industry.

7.2 Inductions

Inductions are a critical step to ensure the safety of persons attending a coupe. Such persons requiring an induction include the contractor's employees, VicForests' staff, log truck drivers, other sub-contractors, DEPI staff, auditors, or any visitors (individuals and groups). The following apply to a Coupe or Log Storage Site:

- (a) Any person allowed to be at a work site must be inducted into the work site;
- (b) An induction must be relevant to those persons attending the work site considering their age, maturity, physical abilities as well as their experience, knowledge and understanding of forest operations;
- (c) An induction must identify relevant hazards and how those hazards are to be managed, controlled or avoided by persons attending the work site;
- (d) An induction must identify the required behaviour of persons attending the work site;
- (e) An induction must identify any additional supervision that may be provided while persons are attending the work site;
- (f) An induction must identify incident and emergency management requirements associated with that work site.

7.3 Reporting Incidents and Investigation

- (a) General health and safety requirements are outlined in this section. Specific health and safety requirements are detailed in the relevant sections of this document.
- (b) Incident Reporting

- (i) All notifiable incidents (as defined by section 37 and 38 of the *Occupational Health & Safety Act 2004*) must be verbally reported immediately it becomes known, to WorkCover and to VicForests and must be investigated by the contractor. Notification in writing is required to WorkSafe and VicForests within 48 hours.
- (ii) All Lost Time Incidents must be verbally reported to VicForests within 24 hours and must be investigated by the contractor. VicForests must then be advised of any corrective action to be taken to prevent the recurrence of the incident. Notification in writing is required to VicForests within 48 hours.
- (iii) The goals of the investigation process are to:
 - Identify the sequence of events leading up to the incident;
 - Identify the contributing factors and root cause;
 - Identify what could be done to prevent a similar incident in the future;
 - Determine the corrective action to be taken, the person responsible and the timelines for implementation;
 - Ensure that statutory reporting requirements can be met.
- (iv) VicForests reserves the right to be part of the accident investigation process or to carry out their own independent investigation. All incidents reported by the public will be investigated by VicForests.
- (v) All serious Near Miss incidents which have the potential for injury or have resulted in damage to machinery or plant must be verbally reported to VicForests within 24 hours, and must be investigated by the contractor. Notification in writing is required to VicForests within 48 hours.
- (vi) All Near Miss incidents must be reported in writing to VicForests within 5 working days.

7.4 **Tree felling**

A Contractor must ensure that:

- (a) any tree which is scarfed is brought to the ground as soon as possible;
- (b) only one tree is scarfed at any time;
- (c) any hung-up tree is brought to the ground as soon as possible;
- (d) no tree is manually fallen into any other scarfed tree in order to push it down to the ground. A contractor must use a machine to clear a hung up tree and a diary entry must be made to record that this has occurred;
- (e) where there is doubt about which direction a tree will fall and it cannot be cleared by a machine, then that tree must not be felled, and a record should be made in the coupe diary.

7.5 **Plant, equipment and machinery standards**

In addition to requirements of legislation, the Industry Standard: Safety in Forestry Operations, Australian Standards and other relevant published codes of practice, the following requirements are mandatory:

- (a) Polycarbonate protective guarding on all machines with cut-off saws must be at least 19mm thick.

7.6 **Minors (Children) at Worksites**

- (a) VicForests prohibits the presence of children and the employment of children, under 15 years of age, on any Coupe, Landing, Log Storage Site, delivery site or log truck. In certain limited circumstances, VicForests may give approval for school groups to visit a Coupe, Landing, Log Storage Site (Refer to clause 7.7. below).
- (b) Where minors aged between 15 and 18 are employed on or visiting a Coupe, Landing, Log Storage Site, delivery site or log truck, the Contractor must ensure that there are

appropriate safety management systems in the relevant work site that take account of a minor's relative immaturity and lack of experience. This would include appropriate induction, supervision and, for employees, training.

- (c) A Contractor must ensure that the requirements of clauses 7.6(a) and (b) are strictly adhered to.

7.7 Management of visiting groups

From time-to-time groups of visitors attend Coupes or Log Storage Sites for various purposes and in various numbers. They may include industry groups, researchers, VicForests' Board members, overseas delegations, school and other youth groups. Attendance of groups requires an additional level of risk management. Quite often members of such groups do not have all of the personal protective equipment that is normally expected of a person attending such work sites but regardless of whether this is the case a Contractor must ensure that:

- (a) All groups attending a work site are first authorised by VicForests.
- (b) The Logging Team Leader or Contractor determines any risk management requirements in conjunction with a VicForests' representative.
- (c) Where prudent for safety reasons, certain aspects of coupe operations stop when groups are present. For example:
 - (i) Cease snagging, log preparation or loading if members of a group are to enter onto a landing.
- (d) There are strict limits on the group's access to parts of a work site:
 - (i) when operations are active;
 - (ii) where other risks exist such as chain-shot or access to log stacks;
 - (iii) where the physical abilities of the group may be limited;
 - (iv) where all appropriate personal protective equipment is not available.
- (e) Where prudent for safety reasons, additional separation is included between the group and active operations, for example:
 - (i) Significantly beyond the standard 2 tree lengths if observing felling operations;
 - (ii) Significantly beyond the standard extended boom length plus half log length (or 12 m) to observe loading operations.

8. THINNING REQUIREMENTS

8.1 Trees to be removed

Unless the Forest Coupe Plan provides otherwise, a Contractor must ensure that;

- (a) subject to the requirements of sub-clause 8.2, every tree specified on the Forest Coupe Plan is removed; and

8.2 Trees to be retained

The Contractor must ensure that:

- (a) thinning operations do not alter the relative mix of forest species as specified on the Forest Coupe Plan; and
- (b) during thinning, all dominant and most co-dominant trees in the coupe are retained, together with every intermediate tree filling a gap in forest cover unless:
 - (i) the tree is on a pre-defined outrow or extraction track; or
 - (ii) a VicForests representative directs otherwise; and
- (c) after thinning is complete, the retained live basal area is no less than the area specified in the Forest Coupe Plan.

8.3 Thinning method

- (a) The Contractor must ensure that:
- (i) any pivot tree used during thinning is:
 - an intermediate or suppressed tree; and
 - is removed after it is no longer needed; and
 - (ii) thinning is conducted by the outrow and bay method; and
 - (iii) outrows are located at approximately right angles to the prevailing contour of the land; and
 - (iv) an outrow is not more than 4.5 metres wide; and
 - (v) a bay is at least 12 metres wide on slopes up to 15 degrees and at least 10 metres wide on slopes greater than 15 degrees; and
 - (vi) any extraction track selected will cause minimal damage to the butts or roots of remaining trees; and
 - (vii) all timber resource felled during thinning which complies with specifications for timber set out in the Licence or timber sale agreement to be supplied from the coupe, is extracted from the coupe, unless the Forest Coupe Plan provides otherwise.
- (b) A Contractor may allow an outrow or extraction track to deviate around any log or stump which is too large to remove with reasonable ease, unless the Forest Coupe Plan provides otherwise.

8.4 **Damage**

Unless the Forest Coupe Plan provides otherwise, the Contractor must ensure that:

- (a) as a result of thinning, not more than 15% of the retained trees which contain, or are likely in the future to contain, merchantable timber, suffer damage. The VicForests representative will regularly assess damage to retained trees across the coupe.

8.5 **Rehabilitation of Extraction Tracks**

Unless the Forest Coupe Plan specifies otherwise, the Contractor must ensure that:

- (a) cross drains are constructed in accordance with Schedule 1 (where applicable), or slash / bark redistributed over outrows and main forwarder tracks.

9. **EXTRACTION (SNIG AND FORWARDING) TRACKS WITHIN COUPES**

9.1 **Location of Extraction Tracks**

- (a) A Contractor must ensure that any extraction track within a coupe is located and used in ways which cause the least possible damage to soil, water quality and retained trees.
- (b) A Contractor must ensure that:
 - (i) no track enters or crosses an excluded area or filter strip, except at a location which has been designated on the Forest Coupe Plan and physically marked on the coupe; and
 - (ii) wherever practicable, tracks are located so as to avoid them converging on a downhill slope; and
 - (iii) any track used during thinning and selection harvesting is constructed with low side slopes and
 - (iv) the coupe is operated in a way which limits as far as possible the number of tracks in use at the same time; and
 - (v) tracks are progressively rehabilitated where appropriate; and
 - (vi) where physical and other environmental factors permit, the total length of extraction tracks within a coupe is minimised.

Note: see also paragraph 11.1(h).

- (c) Where cording and matting is used it should comply with prescriptions in Schedule 7.

9.2 Blading-off

- (a) A Contractor must ensure that no extraction track is bladed-off except where blading-off has been both authorised by a VicForests representative and recorded on the coupe diary.

9.3 Drainage and Rehabilitation

- (a) A Contractor must ensure that each extraction track:
 - (i) is located and maintained in a way which results in the least possible channelling of water and accumulation of water in hollows; and
 - (ii) subject to paragraph (b), is either out-sloped or cross-drained, unless otherwise specified on the Forest Coupe Plan, immediately after extraction is complete; and
 - (iii) is progressively rehabilitated; and
 - (iv) is drained prior to substantial rainfall where such rainfall was forecast.
- (b) Sub-paragraph (a)(ii) does not apply to an out-row track which, after or during thinning, is covered with debris or slash.
- (c) Subject to paragraph (d) and (e), a Contractor must construct cross-drains:
 - (i) at intervals no greater than those specified in Schedule 1; and
 - (ii) at approximate right angles to the water flow across the track. The drain should be at an angle to best intercept water, and should be on a slight grade (1-3%) to pass the water from one side of the track to the other; and
 - (iii) where the run-off either filters through undisturbed forest soil or into natural drainage channels. If this is not possible the discharge should be directed onto solid ground, not fill; and
 - (iv) on any track built on a drag line for cable harvesting which has ruts deeper than 200 millimetres; and
 - (v) generally at a height above the surface of the track of no less than 0.3 metres on a slope of up to 10° and 0.5 metres on a slope greater than 10°; and
 - (vi) to include an invert, at least 0.2m deep, below the surface of the track;
 - (vii) from non-flammable materials (earth and rock) and not from bark.
- (d) Cross drains are not required on snig tracks that have been corded and matted. All cording and matting on snig tracks is to be lifted and aerated to facilitate burning. The majority of the material is to be kept on the track to block any flowing water.
- (e) A Forest Coupe Plan may include any other specifications concerning drainage and rehabilitation of an extraction track which a VicForests representative considers appropriate.

9.4 Snigging on roads

A Contractor must ensure that no snigging occurs on or across any road or structure maintained by the DEPI Secretary except:

- (a) during the construction of any road by the Contractor; or
- (b) in special circumstances specified in the Forest Coupe Plan.

9.5 Stream Crossings

A Contractor must ensure that:

- (a) no extraction track is constructed across a permanent stream unless it has been both recorded on the Forest Coupe Plan and physically marked on the coupe by a VicForests representative; and

- (b) any crossing is properly and appropriately constructed, in accordance with sub-clause 12.9, and to a standard which a VicForests representative considers appropriate; and
- (c) any crossing is removed promptly after harvesting is complete, unless the Forest Coupe Plan provides that the crossing is to remain.

10. LOADING BAYS

10.1 Loading Bays (Thinning)

A Contractor must ensure that thinning loading bays:

- (a) do not exceed 600 square metres (20m x 30m) in size;
- (b) are rehabilitated by placing slash back over the site. If the size of the loading bay exceeds this size then the site is to be rehabilitated according to the landing requirements.

11. LANDINGS

11.1 Location of Landings

A Contractor must ensure that:

- (a) no landing is constructed in an excluded area; and
- (b) any landing is located at least 40 metres from any permanent stream, or wetland; and
- (c) any landing is located at least 20 metres from any temporary stream and any drainage line; and
- (d) any landing is :
 - (i) located at least 40 metres from any permanent Class 5A or Class 5B road; and
 - (ii) at least 20 metres from any permanent Class 5C or lower class of road, unless the VicForests representative has approved a closer location in the Forest Coupe Plan.
- (e) every landing is constructed at a location specified on the Forest Coupe Plan; and
- (f) is constructed in accordance with the alignment of the access road to that landing; and
- (g) no road is used as a landing or to load logs, except during the construction of a road, or where the Forest Coupe Plan authorises that use; and
- (h) wherever practicable, extraction tracks are located in ways which avoid them converging downhill to a landing; and
- (i) landings are located to eliminate or minimise the presence of hazards that need to be managed.

11.2 Construction and Maintenance of Landings

A Contractor must ensure that:

- (a) each landing is less than:
 - (i) 0.5 hectares in area, in any ash-type coupe; and
 - (ii) 0.3 hectares in area, in any mixed species, unless otherwise specified on the Forest Coupe Plan; and
- (b) the least possible earth-works are undertaken to construct a landing; and
- (c) any soil or other material moved during the construction or use of a landing is not placed or accumulated within 3 metres from any retained tree; and
- (d) any material removed from the landing area is not placed where there is a risk it may enter a stream or wetland: see paragraph 11.7(a); and

- (e) all topsoil and vegetation is removed from the site of the landing and the topsoil maintained in a stockpile, clear of logging debris and undisturbed by machinery, unless:
 - (i) the Forest Coupe Plan provides otherwise; or
 - (ii) cording can be placed directly onto the pre-existing ground surface.
 - (iii) The landing is on steep slopes (15-20 degrees) in which case topsoil may be stored in benches within the landing supported by stumps and bedlogs.
- (f) a landing is not bladed-off unless blading-off has been both authorised by a VicForests representative and recorded on the Forest Coupe Plan; and
- (g) all drainage from a landing is discharged into undisturbed or uncompacted soil, at least 20 metres in width, before it flows into any stream, wetland or drainage line
- (h) a landing is not covered with bark pads without underlying cording; and
- (i) landing location is considered to provide for safe operation; and
- (j) landing design allows for safe access and egress for the range of truck and trailer configurations; and
- (k) only employees or sub-contractors who have successfully completed construction induction training may construct or supervise the construction of landings.

11.3 Landing Operation

A Contractor must ensure that all activities carried out on landings either by people or machinery are:

- (a) separated, either by appropriate barriers, space or timing to ensure the risk to safety is minimised as far as reasonably practical; and
- (b) conducted in accordance with the Contractor's procedures for managing landings; and
- (c) covered by adequate communication systems to ensure that all who operate on a landing can communicate with each other when necessary.

11.4 Loading

- (a) Loading Operations:
 - (i) Whilst loading is in progress no person will be within the work zone of the loader. There must be a Designated Safe Area made clear to all operators on and visiting the landing;
 - (ii) It may be agreed that the cab is a Safe Area, but if not in the truck cab then the driver (or any other person at the landing) must stand in a designated Safe Area which is in clear view of the operator away from the truck;
 - (iii) The chosen Safe Area made by the harvesting contractor after consultation with the truck operator must be recorded on the Landing Hazard Identification Checks Sheet – Landing Map area. It is expected that this will be clearly marked;
 - (iv) The cab must not be the designated Safe Area for the driver if logs are to be loaded over the front of the cab;
 - (v) The work zone for the loader is the maximum reach of its boom plus ½ log lengths. e.g. if the log being loaded is 11m then all person's on the landing should be at least 5.5m away plus the swing radius of the loader;
 - (vi) When loading residual wood all persons including the truck driver must remain in the agreed Safe Area;
 - (vii) The Safe Area for the driver, or other person/s at the landing, must be documented in the Landing Hazard Identification Check List-Landing Map area;
 - (viii) All personnel on site must comply with all reasonable direction of the loader operator whilst loading is taking place;

- (ix) Radio communication will, where possible, be made available for the driver (or any other person on the landing) to communicate with loader operator;
- (x) If radio communications are not available for unforeseen circumstances then oral or visual communication must be established. The driver (or any other person on the landing) must not approach a truck or loader whilst still operating;
- (xi) Chain of Responsibility compliance must be adhered to at all times including the Best Practice Guide for the Haulage of Timber in Log Form or any other updates as requested by VicForests.

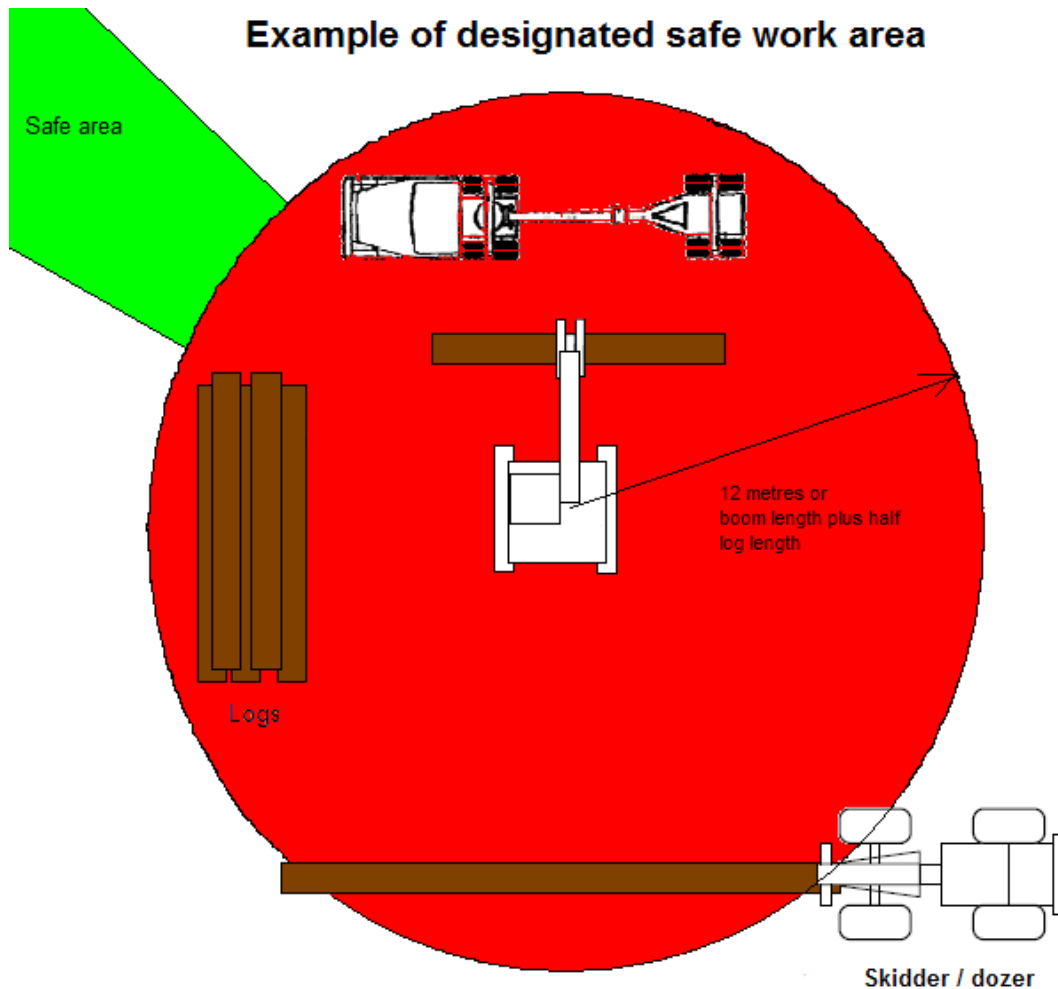

- (b) Loader Responsibilities:
- (i) If at any stage the loader operator is not certain of the location of any person at the landing then loading must stop;
 - (ii) Loading should be undertaken in a manner where logs are lifted over the top of stanchions up to a height of 4.5m (i.e. loader must have that capacity) while they are fully contained within the lifting mechanism. The owner of this equipment is responsible for maintaining the equipment in safe operating condition and ensuring that it is only operated by an accredited operator;
 - (iii) When the loader is not in operation the boom is to be lowered to the ground;
 - (iv) When allowing a driver to approach a sawlog to record details on the log docket then the log must be enclosed in the grapple and the grapple must be resting on the ground;
 - (v) Loader operator must follow all reasonable instructions from the driver associated with arrangements of the logs on the truck and the crowning of the load.

11.5 Bark Disposal

- (a) Unless the Forest Coupe Plan provides otherwise, a Contractor must ensure that, where a log is debarked on the coupe:
 - (i) all bark is re-distributed throughout the coupe:
 - during harvesting - in piles not exceeding 4 square meters (ground area) and 10 m³ total; and
 - in the case of thinning – in piles not exceeding 1 m³; and
 - (ii) all piles of re-distributed bark are placed at least 10 m from the coupe boundary;
 - (iii) a grapple must be used, where available, for the redistribution of bark;
 - (iv) bark must not be deliberately placed on snig tracks (outrows in thinning exempt).
- (b) Where it is not appropriate to re-distribute bark, but where it is necessary to heap for burning, a Forest Coupe Plan may require a Contractor to loosely heap bark:
 - (i) which is aerated and free of soil; and
 - (ii) at a location that maximises the area of receptive seedbed; and
 - (iii) when approved by a VicForests Representative on the Forest Coupe Plan.

11.6 Drainage

A Contractor must ensure that:

- (a) a landing is constructed and drained to prevent water accumulating; and
- (b) all drainage from a landing is discharged into undisturbed or uncompacted soil, at least 20 metres in width, before it flows into any stream, wetland or onto any drainage line.

11.7 Rehabilitation

A Contractor must ensure that:

- (a) promptly after harvesting is completed, all logs remaining on a landing are cleared and any accumulated debris and bark is re-distributed in the coupe, unless the Forest Coupe Plan provides otherwise; and
- (b) if a conventional landing will not be re-used for other harvesting operations, it is promptly rehabilitated by completing the following activities:
 - (i) levelling and draining the area of the landing.
 - (ii) as a minimum, ripping (including cultivation by an excavator) to a depth of at least 0.4 metres, in lines no more than 2 metres apart during dry conditions, unless:
 - the presence of rock prevents ripping; or
 - the depth of topsoil is inadequate for ripping; or
 - alternative prescriptions are specified on the Forest Coupe Plan.
 - (iii) re-spreading all topsoil which has been set aside to rehabilitate the landing with the aim of maximising the area covered by a reasonable depth of topsoil. This should be undertaken after ripping unless otherwise directed by a VicForests representative.
 - (iv) re-spreading all sawdust to a depth of no more than 3 cm.
 - (v) undertaking any other action to rehabilitate the landing that may be specified in the Forest Coupe Plan.
- (c) if a corded and matted landing will not be re-used for other harvesting operations, it is promptly rehabilitated by completing the following activities:

- (i) as much matting as possible should be removed from the landing and spread around the coupe;
- (ii) the cording should be removed (preferably salvaged);
- (iii) heaping and aerating excess bark and broken pieces of cording that are unable to be redistributed around the coupe adjacent to the landing to facilitate burning and create areas of receptive seedbed between the heaps;
- (iv) ripping and cultivation will be required if:
 - machinery operations during removal of cording and matting have compacted the soil; or
 - if the landing was benched before being corded.
- (d) all rehabilitation works required by the relevant coupe monitoring record (harvesting) and Forest Coupe Plan have been completed.

12. ROAD CONSTRUCTION AND MAINTENANCE

12.1 Responsibility for Constructing, Upgrading and Maintaining roads

- (a) A Contractor must construct and maintain all in-coupe roads required to harvest the coupe. Specific maintenance standards may be specified in the Forest Coupe Plan.
- (b) VicForests is responsible for arranging the construction and maintenance of coupe-access roads. VicForests will negotiate with the contractor regarding implementation of these works.
- (c) VicForests is responsible for arranging the construction, upgrading and maintenance of any other State Forest road (permanent or otherwise) required for the haulage of timber resource from coupe to Customer.

12.2 Location, Design and Period of Construction

A Contractor must:

- (a) wherever possible, use existing roads to obtain access to a coupe and to cart logs; and
- (b) only construct a new road:
 - (i) specified on the coupe map in the Forest Coupe Plan; and
 - (ii) after the alignment of the road has been both physically marked or otherwise designated and approved by a VicForests representative; and
 - (iii) during any period of time which may be specified on the Forest Coupe Plan; and
 - (iv) which is of Rural Class 5C or 5D in accordance with the guidelines in Schedule 2 unless otherwise specified in the Forest Coupe Plan; and
 - (v) which crosses a stream or drainage line at a location specified in the Forest Coupe Plan; and
- (c) prepare a road pavement if the Forest Coupe Plan so requires; and
- (d) must ensure that only employees or sub-contractors who have successfully completed construction induction training may construct or supervise the construction of roads.

12.3 Blasting

- (a) A Contractor must ensure the use of explosives on State forest is undertaken in accordance with the appropriate Safety Systems and following all VicForests guidelines and directions.
- (b) All planned blasting operations must be approved by VicForests before blasting operations can commence.

12.4 **Grade**

- (a) Subject to paragraph (b), a Contractor must construct each road with a maximum ruling grade which does not exceed the grade specified in Schedule 2.
- (b) A Contractor may construct not more than 15% of the total length of a road, with a maximum excess grade specified in Schedule 2, unless the Forest Coupe Plan provides otherwise.

12.5 **Clearing**

- (a) A Contractor must ensure that:
 - (i) clearing of the site of any proposed road does not commence until the road alignment and any excluded area or retained tree near the road alignment are both physically marked or otherwise designated on the coupe and approved by a VicForests representative; and
 - (ii) the site of the road is cleared and all merchantable logs recovered and all debris removed from the area which will be occupied by the proposed road pavement, shoulders and table drain before construction of the road commences; and
 - (iii) each site is cleared at least for the relevant horizontal distance specified in Schedule 3, but for no greater distance than any maximum clearing width specified in the relevant Forest Coupe Plan; and
 - (iv) wherever a road crosses or adjoins an excluded area, clearing width must be minimised (in reference to Schedule 3), physically marked on the ground and approved by a VicForests representative; and
 - (v) no stump, log or other debris is buried in the formed width of a road; and
 - (vi) all debris is cleared from the formed width of the road; and
 - (vii) any debris cleared adjacent to an excluded area, is deposited in accordance with the Forest Coupe Plan.
- (b) A Contractor who improves an existing road may push any non-merchantable logs beyond the slashable verge of the road into the forest unless the Forest Coupe Plan provides otherwise,

12.6 **Earth-Works**

A Contractor must ensure that:

- (a) the least possible earth-works are undertaken to construct a road; and
- (b) any material removed from the site is not placed where there is a risk of it entering a stream or wetland; and
- (c) if the Forest Coupe Plan so requires, top soil is removed and kept and maintained in a stockpile, clear of logging debris and machinery, for rehabilitating the site, in accordance with the Forest Coupe Plan; and
- (d) any batter requiring drainage or stabilisation is constructed in accordance with any specifications in the Forest Coupe Plan. Batter slopes should be constructed at an angle to cause the least possible amount of slumping; and
- (e) fill batters do not cover the base of live trees unless authorised by a VicForests representative.

12.7 **Drainage**

12.7.1 Drainage Principles

A Contractor must ensure that:

- (a) in-coupe roads are effectively drained (for example, crowned or sloped) and run-offs, cross-drains or culverts are constructed:
 - (i) at the intervals specified in Schedule 4, unless the Forest Coupe Plan otherwise requires; and

- (b) effective drainage is placed approximately 20 metres from permanent or temporary streams; and
- (c) drainage from a road does not discharge onto any road, track, exposed soil, or drainage line or directly into a stream or wetland; and
- (d) any drainage from a road discharges onto either:
 - (i) a strip of undisturbed vegetation at least 20 metres wide; or
 - (ii) a rock spill; or
 - (iii) some other structure which dissipates the velocity of drainage flows; and
- (e) the least possible drainage from a road is discharged inside any stream buffer or filter strip through which the road passes; and
- (f) if a VicForests representative determines there is a risk that drainage may be discharged directly into a stream or wetland, a silt trap is constructed to receive all of that drainage.

12.7.2 Time of Construction

A Contractor must ensure that:

- (g) any work required under this clause is executed while the road is being formed; and
- (h) a temporary sediment trap is constructed at any point specified in the Forest Coupe Plan; and
- (i) a barrier is erected at the entrance to the partly-constructed road, which prevents access by vehicles; and
- (j) Road construction is undertaken when rainfall and soil conditions minimise the risk of erosion and offsite impact of water quality but takes account of requirements for adequate soil moisture to achieve desirable compaction and stabilisation of the sub-grade.

12.7.3 Construction of Silt Traps

Where a silt trap is required, a Contractor may construct a trap:

- (k) by placing a barrier (such as logs) roughly parallel to the road at a point where drainage discharges from the road, across the flow of drainage; or
- (l) where drainage discharges from a road into a stream or wetland buffer across the end of the relevant table drain.

12.7.4 Construction of Table Drains

A Contractor must ensure that any table drain:

- (m) allows water to flow, without ponding; and
- (n) is created by extending the road when it is formed, and not by subsequent excavation; and
- (o) includes run-offs of sufficient length to allow the table drain and run-offs to be cleaned; and
- (p) on a road constructed in soil which, has a high erosion hazard as indicated on the Forest Coupe Plan, is supported by rock or otherwise stabilised.

12.7.5 Construction of Cross-Drains

A Contractor must ensure that any cross-drain is constructed at an angle sufficient to discharge any water from the surface of the road.

12.7.6 Construction of Culverts

Unless the Forest Coupe Plan provides otherwise, a Contractor must ensure that, each culvert:

- (q) be a minimum 375mm in diameter for permanent roads; and
- (r) be a minimum 300mm in diameter for temporary roads; and
- (s) is held in place and protected from erosion by either sandbags, timber, concrete or rock, placed at the head of and at the point of discharge from, the culvert; and

- (t) on a Class 5C road, is constructed to include a road sump, placed within a side-cut and located within the table drain; and
- (u) is located at a depth of at least the diameter of the drainage pipe, below the surface of the ground.

12.8 Maintenance

A Contractor must ensure that:

- (a) each road constructed by the Contractor is properly maintained to ensure the least possible:
 - (i) erosion of the road surface; and
 - (ii) discharge of turbid water to streams or wetlands; and
- (b) any soil windrow erected on the outside of a road is breached at regular intervals, except where the windrow protects a fill; and
- (c) each road drain is kept free of debris; and
- (d) no blading-off occurs on a temporary road unless blading-off has been approved by a VicForests representative and recorded in the Forest Coupe Plan; and
- (e) no blading-off occurs on a permanent road unless blading-off has been approved by the DEPI Secretary in writing and recorded in the Forest Coupe Plan.

12.9 Stream and Drainage Line Crossings

A contractor must construct stream or drainage line crossings:

- (a) of type and specifications described in the Forest Coupe Plan, and
- (b) at a location specified on the coupe map in the Forest Coupe Plan and physically marked in the field.
- (c) in a manner which minimises the amount of woody debris entering the stream channels (where it can float downstream, alter the watercourse and/or lodge in culverts).

12.10 Bridges

A Contractor must ensure that:

- (a) any bridge is constructed in accordance with any specifications set out in the Forest Coupe Plan; and
- (b) any bridge is designed and constructed with appropriate load bearing capacity and to withstand a 1 in 20 year rainfall event or as specified on the Forest Coupe Plan; and
- (c) gravel surfacing with a low sediment generating potential is applied to the road area on the 20m approaches to a bridge; and
- (d) any earth-topped bridge is constructed with:
 - (i) geotextile or a similar cloth filter; and
 - (ii) sideboards; and
 - (iii) gravel with a low sediment generating potential.
- (e) any clearly defined channel is not constricted by a bridge; and
- (f) earth borrow for bridge construction is not obtained from a stream or wetland buffer; and
- (g) the least possible disturbance is caused to soil under or adjacent to any stream, wetland or drainage line; and
- (h) excavations, sills, abutments, stringers and girders are made or placed above the high watermark of the stream, wetland or drainage line; and
- (i) any earth embankment constructed for the approach to any bridge:
 - (i) complies with the requirements of sub-clause 12.6 and 12.7; and

- (ii) is protected from erosion by natural groundcover, a retaining wall, a bulkhead or a rock surface; and
- (j) if a temporary crossing is required to carry machinery while a bridge is constructed:
 - (i) unless the bed of the stream, wetland or drainage line is capable of bearing the weight of that machinery without being damaged, a corduroy crossing of large logs is constructed; and
 - (ii) the temporary crossing is removed and any access track to it barred, when construction is complete,
 unless the Forest Coupe Plan provides otherwise.

12.11 Crossings

A Contractor must ensure that:

- (a) a ford is constructed where it is required by the Forest Coupe Plan; and each ford:
 - (i) has a base and entry points constructed of rock, concrete, heavy timber or other erosion-resistant material; and
 - (ii) is as wide as the crossing place will allow; and
 - (iii) does not project above the bed of the stream or wetland in a way which may prevent the passage of aquatic fauna.
- (b) a log fill crossing is constructed where it is required according to the Forest Coupe Plan and must:
 - (i) only be used on snig track (extraction tracks); and
 - (ii) be removed before provisional or final clearance of coupe.

12.12 Culverts

A Contractor must ensure that:

- (a) any culvert is designed and constructed:
 - (i) to accommodate a 1 in 10 year rainfall event or as specified in the Forest Coupe Plan; and
 - (ii) not to project above the bed of a stream, wetland or drainage line in a way which may prevent the passage of aquatic fauna; and
- (b) any water diverted from its natural course by a culvert is returned to that course over a flume, rock spill or other hard surface; and
- (c) any fill face upstream or downstream from a culvert is protected in a way which prevents erosion.
- (d) where the required culvert is greater than 750 millimetres, the passage of fish on permanent streams is considered by:
 - (i) constructing a fish ladder from mesh; or
 - (ii) using a larger than required culvert and installing in such a way as to assist the passage of fish.

12.13 Temporary Road Closure

- (a) An Authorised DEPI Officer is the only person with the authority to temporarily close roads.
- (b) Roads closures may be implemented by an Authorised DEPI Officer on any road in a State forest:
 - (i) without warning because of:
 - wet weather; or
 - extremely dry weather; or
 - unsafe conditions.
 - (ii) through a DEPI approved Road Closure Plan prepared by VicForests on behalf of the Contractor when activities on or near the road may cause danger to those using the road. Activities include:

- burning to facilitate regeneration or to reduce fuel; and
 - roadworks; and
 - tree felling; and
 - suspending cables above a road during cable logging; and
 - landing logs onto a road.
- (c) A contractor must, where appropriate:
- (i) request VicForests to provide gates or other appropriate barriers; and
 - (ii) ensure the road is closed to public use pursuant to the approval from DEPI; and
 - (iii) ensure gates are kept closed (where applicable); and
 - (iv) ensure appropriate signage is in place (where applicable); and
 - (v) ensure every person working on a coupe complies with any directions given by an Authorised DEPI Officer when a road is closed

12.14 Permanent Road Closure

- (a) A Contractor must ensure that a road which VicForests requires the Contractor to permanently close when harvesting in a coupe is complete:
- (i) is promptly closed to all vehicles by a log, gate or earth barrier; and
 - (ii) is cross-drained at least to the standards specified in Schedule 4; and
 - (iii) if the road is not cross-drained in accordance with paragraph (ii), is treated in such a manner as a VicForests representative considers appropriate and is recorded on the Forest Coupe Plan.

12.15 Traffic Management

- (a) A contractor must when working in the vicinity of public roads, ensure the risks to road users are appropriately managed and, where appropriate:
- (i) Implement the VicForests Traffic Management Plan; and
 - (ii) ensure every person working on a coupe complies with any directions given by the VicForests representative.

12.16 Removal and Rehabilitation of Bridges, Crossings and Culverts

Except where the Forest Coupe Plan provide otherwise, a Contractor must ensure that:

- (a) every temporary bridge and culvert is removed promptly when either:
 - (i) harvesting is complete; or
 - (ii) where rehabilitation works are required, when those works are complete; and
- (b) the approaches to any temporary bridge are cross drained at least to the standards specified in Schedule 4; and
- (c) the site of each temporary bridge and culvert is rehabilitated to a VicForests representative's satisfaction.

12.17 Moving Heavy Machinery on Forest Roads

- (a) A contractor must not snig forest produce or move heavy machinery along or across a forest road unless approved by a VicForests representative.
- (b) If approval is granted, a Contractor must ensure:
 - (i) the risk to machine operators and other road users is minimised;
 - (ii) the integrity of the road is not compromised;
 - (iii) an escort vehicle with appropriate signage and lighting travels in front of any machinery being walked, or the appropriate traffic management plan is in place;
 - (iv) the road shoulders are used for walking in preference to the road surface;

- (v) that, wherever possible, an excavator follows the rear to roll the cleat marks in.

13. QUARRIES, BORROW PITS AND FILL DISPOSAL AREAS

- (a) A Contractor must not construct or use a rock quarry, borrow pit or fill disposal area except:
- (i) when the Forest Coupe Plan so requires; and
 - (ii) in accordance with the *Extractive Industries Development Act 1995* and the *Extractive Industries Development Regulations 1996*.
- (b) A Contractor must, before excavating any proposed rock quarry, borrow pit or fill disposal area:
- (i) harvest and recover all merchantable timber from the site; and
 - (ii) heap all debris from the site within the clearing; and
 - (iii) stockpile all topsoil from the site, unless the Forest Coupe Plan provides otherwise.
- (c) A Contractor must ensure that any drainage from a rock quarry or borrow pit:
- (i) is discharged into an area of undisturbed vegetation at least 20 metres wide; and
 - (ii) if the flow is concentrated, is discharged through one or more holding areas or sediment traps, before it is discharged into an area of undisturbed vegetation referred to in sub-paragraph (i).
- (d) A Contractor who operates a borrow pit:
- (i) must ensure that:
 - the least possible area of the pit is open at any time; and
 - all rubbish (including waste oil, drums and machinery parts) is removed from the pit; and
 - the pit is rehabilitated progressively, in accordance with the Forest Coupe Plan.

14. PREPARATION AND MEASUREMENT OF LOGS

14.1 Work zones

A Contractor must ensure that:

- (a) the work area for each activity at the landing must be separated (ie people from machinery), either by appropriate barriers, space or timing to ensure the risk to safety is minimised as far as reasonably practical.

14.2 Log preparation

Unless the Forest Coupe Plan specifies otherwise, a Contractor must ensure that:

- (a) all logs are inspected and marked by an accredited log grader; and
- (b) the first cut is to be made at the sawlog / pulp interface and may be done mechanically if previously marked; and
- (c) sawlog grade lengths are marked prior to cutting; and
- (d) the use of cut-off saws for the preparation of sawlogs must meet acceptable operating standards for mechanical damage, wastage and short log sections as determined by VicForests, otherwise the use of cut-off saws may be prohibited for a set period; and
- (e) logs are elevated and positioned on notched logs to enable the log grader to safely and accurately grade, cut and mark the sawlogs; and
- (f) preferred sawlog lengths are only cut where grade and volume are not compromised (2.7 m is the minimum sawlog length); and

- (g) short lengths of sawlog less than 2.7 m are not cut from sawlog to waste; and
- (h) limbs and slovens are flush cut; and
- (i) logs to be sold by weight are branded before being stacked to facilitate auditing; and
- (j) logs are cut flush at right angles to the log barrel (up to 10 degrees); and
- (k) logs are to be fully debarked.

14.3 Determining if timber is not merchantable

- (a) To determine whether a felled tree contains merchantable timber, the Contractor must:
 - (i) make proving cuts:
 - at the head and, if necessary, along the length of the bole or limb of a tree; and
 - which expose at least three-quarters of the cross-section of the bole or limb; and
 - (ii) make such other proving cuts as a VicForests representative directs.
- (b) If there is a difference of opinion between a VicForests representative and a Contractor about whether any part of a tree is, or is not, merchantable timber, a VicForests representative must:
 - (i) determine the matter; and
 - (ii) mark the log with a VicForests' brand signifying that VicForests take responsibility for the decision.

14.4 Marking

- (a) A Contractor must ensure that an accredited grader marks on the end of the log on all logs sold by volume with:
 - (i) length
 - (ii) centre diameter under bark
 - (iii) species (refer to Schedule 11)
 - (iv) grade
 - (v) log tag (only log tags approved by VicForests)
- (b) A Contractor must ensure that an accredited grader marks all sawlogs sold by weight with:
 - (i) species, only when multiple species are present (refer to Schedule 11)
 - (ii) a unique identifier (the accredited graders hammer, log tags or other means)
- (c) A Contractor must ensure that an accredited grader marks at least 70% of a load of residual logs sold by weight with:
 - (i) a unique identifier (the accredited graders hammer, log tags or other means)
- (d) A Contractor must not remove from a coupe any log(s) which the VicForests representative has designated to remain, until a VicForests representative gives authority to remove such log(s).
- (e) If an Accredited Log Grader cannot determine the species of a log, "MS" or "AS" must be marked on the log and recorded in the corresponding log docket.
- (f) A Contractor must allow a VicForests representative to check and if necessary to correct the marking of any log in a coupe at any time. The VicForests representative may initial a docket to show the customer they have checked and accept responsibility for the log grades as shown on the docket.

14.5 Measuring Logs by Volume

- (a) A Contractor must ensure that where timber resource is to be charged for by volume:
 - (i) the length of a log is measured as the shortest distance from end to end rounded down to the nearest 0.1 metre; and

- (ii) the diameter of a log is measured at the mid-point under bark by a diameter tape or other means approved by a VicForests representative rounded down to the nearest centimetre; and
 - (iii) if there is a knot or other defect at the mid-point of any log, the diameter recorded is the average of the diameter measured on either side of that defect; and
 - (iv) all equipment used to measure logs has legible markings and is accurate.
- (b) The contractor must ensure that measuring equipment is calibrated at least once a day to ensure measurements can be carried out in an accurate manner.
 - (c) A VicForests representative may, at any time at the Contractor's cost, determine the accuracy or otherwise of any measuring equipment used by a Contractor.
 - (d) A Contractor must not use any equipment which a VicForests representative finds to be inaccurate.

14.6 Measuring Logs by Weight

- (a) A Contractor must ensure where logs are to be charged for by weight, that each load is either:
 - (i) in the case of logs directly dispatched from the coupe to a VicForests' customer:
 - weighed by an instrument as agreed by VicForests' and the customer at a location approved by VicForests in writing; or
 - weighed at a public weighbridge, at a location approved by VicForests in writing; and
 - (ii) in the case of a log carted to a Log Storage Site, where no weighing instrument or public weighbridge is available, has its weight estimated by a method approved by a VicForests representative and the weight or estimated weight is duly recorded.
- (b) A Contractor must at such intervals as a VicForests representative requires, provide, in writing evidence acceptable to the VicForests representative, that any weighing instrument used by the Contractor:
 - (i) complies with the requirements of the *Trade Measurement Act 1995*; and
 - (ii) is currently calibrated and certified as measuring accurately; and
 - (iii) cannot be used to record weights incorrectly or fraudulently.
- (c) A Contractor must ensure that the measurement of gross and tare weights is done in a consistent manner (for example, with the driver and any passengers either in or out of the truck on both occasions); and
- (d) A Contractor must ensure that no fuel or other weight is added, or any other change made to a truck after the gross weight and before the tare weight is measured; and
- (e) A Contractor must ensure that the tare weight for any truck is measured as soon as possible after the gross weight is measured and:
 - (i) in the case of measuring equipment used by the Contractor in a mill yard, before the truck leaves the yard; or
 - (ii) in the case of measurement by a public weighbridge, when the truck next makes the return journey; and
- (f) A Contractor must ensure that a VicForests representative is granted unrestricted access to:
 - (i) any weighbridge report or record of transaction; and
 - (ii) independently verify that any weighing instrument provided by the VicForests' customer is measuring accurately,
 if a VicForests representative so requests in writing; and

- (g) A Contractor must ensure that logs are carted and weighed within such reasonable time as is determined by a VicForests representative, after they are felled; and
- (h) Where specified in the Forest Coupe Plan, a Contractor must ensure that any logs which may have partly dried out are:
 - (i) carted separately from green logs; and
 - (ii) recorded as partly dried out;
 where a different conversion factor has been provided by VicForests.
- (i) The Contractor must promptly advise a VicForests representative when the Contractor becomes aware that any weighing instrument used by the Contractor is functioning incorrectly.
- (j) If a VicForests representative is of the opinion that:
 - (i) any weighing instrument used by a Contractor is functioning incorrectly; or
 - (ii) data obtained about the weight of logs may be inaccurate for any reason, the VicForests representative may elect to use some other mechanism for calculating timber charges while the incorrect function or inaccurate data persist, and the Contractor must meet any incremental costs incurred by VicForests.

14.7 Recording Timber Resource – Electronic Dockets (Primary System)

VicForests primary log docket management system of capturing delivered load information is via electronic handheld units.

- a) A Contractor must ensure that:
 - (i) each load must have a separate docket (i.e. two or more Buyer/destinations on a load will have more than one log docket); and
 - (ii) a VicForests approved delivery docket is used; and
 - (iii) dockets are to be completed at the time of loading; and
 - (iv) ensure that the Buyers Copy of the docket remains with the Buyer; and
 - (v) ensures that a Buyers' Representative signs the Receipt at the bottom of the electronic docket print out upon delivery; and
 - (vi) The haulage Contractor retains the signed copy of the electronic docket.
 - (vii) In the event that the Buyer is unable to acknowledge receipt at the time of delivery the following will occur:
 - Truck driver will complete date and time delivered and writes "Unattended" in the customer signature space.
 - Truck driver to leave customer copy in a secure location
 - Buyer to return a signed copy within 7 days to the relevant VicForests Office.
 - At month end. If VicForests identifies log dockets with no customer signature or marked "Unattended" the Buyer will be contacted to provide signed confirmation.
- (b) The contractor must ensure that all logs on a load are recorded on the log docket
- (c) The Contractor must allow a VicForests representative to check and, if the VicForests representative considers it necessary, to correct the recording of any timber resource at any time.
- (d) A Contractor must ensure that each log docket must have the following items printed on it and are legible prior to delivery:
 - (i) Each Log (Measured Sale):
 - Number (one if it is multi graded)
 - Species (Product)
 - Grade

- Length (m)
 - Diameter (cm)
 - Volume (m³ gross)
 - Total Volume (m³ gross)
- (ii) Each Load:
- Barcode (1D for weighed loads and 2D for measured loads)
 - Docket Number
 - Dispatch Date and Time
 - Forest Operation (Coupe Name)
 - Coupe Number
 - Harvesting Contractor
 - Buyer & Delivery Destination
- (iii) H&H Chain of Custody Requirement:
- Haul Contractor
 - Truck Registration & Trailer Type
 - Legal Gross Vehicle Mass
 - Load Weight (Truck Scales)
 - Driver Name
- (iv) Destination Chain of Custody Requirement:
- Dispatch Date and Time
- d) After delivery of the load a contractor must ensure that the load is registered as delivered on the handheld.

14.8 Recording Timber Resource – Log Dockets (Secondary System)

In the event of failure of the handheld device or printer, a paper log docket is to be completed.

- (a) A Contractor must ensure that:
- (i) a delivery docket is correctly completed and legible for every load of timber resource before that load leaves a coupe or Log Storage Site; and
 - (ii) a VicForests approved delivery docket is used; and
 - (iii) unused delivery dockets are kept secure; and
 - (iv) delivery dockets within a docket book are used in their numerical sequence; and
 - (v) any missing delivery docket can be accounted for; and
 - (vi) dockets are to be written out at the time of loading; and
 - (vii) if a mistake is made in completing a delivery docket, the error is crossed out with a single line through the mistake. Correct information is entered on the next line and the alteration is initialled by the Contractor; and
 - (viii) if a delivery docket becomes unusable (due to damage), it is:
 - crossed through and marked 'CANCELLED'; and
 - marked with the number of the replacement docket; and
 - attached to the new docket.
 - (ix) a VicForests representative is promptly notified if the original copy of any delivery docket is lost or destroyed; and
 - (x) the original copy of every delivery docket for every load of timber resource delivered to any delivery site during any period specified by a VicForests representative is made available at a location to be nominated by VicForests within 2 working days of the date of delivery; and

- (xi) each delivery docket book is returned to a VicForests representative within 7 working days after the last delivery docket in the book has been used; and
 - (xii) where required by a VicForests representative, any unused part of a delivery docket book is returned to the VicForests representative within 7 days after harvesting in a coupe is completed.
- (b) The Contractor must allow a VicForests representative to check and, if the VicForests representative considers it necessary, to correct the recording of any timber resource at any time.
- (c) A Contractor must ensure that where timber resource is to be charged for by volume, each log docket has the following items recorded clearly in numerals and capital letters on it prior to removal from the log landing:
- (i) Each Log:
 - Log Number
 - Species (Product)
 - Grade
 - Length (m)
 - Diameter (cm)
 - Volume (m3 gross)
 - Total Volume (m3 gross)
 - (ii) Each Load:
 - Log Grader Number(s)
 - Date and time of Dispatch
 - Operations Area
 - Coupe Name
 - Coupe Number / Address
 - Buyer Name
 - Delivery Destination
 - Harvest Contractor
 - Log Grader Number
 - Cartage Contractor
 - Truck Registration and Trailer Type
 - Load Weight (as determined by truck scales)
 - Load weighed by
 - Load measured by
 - Load loaded by
 - Load transported by
 - Harvest Rep Signature
 - Haul Rep/Driver Signature
 - Date and time of Delivery
 - Load unloaded by
 - Customer Rep Signature
- (d) A Contractor must ensure that where timber resource is to be charged for by weight, each log docket has the following items recorded clearly in numerals and capital letters on it prior to removal from the log landing:
- (i) Date and time of loading
 - (ii) Job Number

- (iii) Job Type (To Mill / To Log Storage / From Log Storage)
- (iv) Supervising Centre
- (v) Coupe Name
- (vi) Coupe Number / Address
- (vii) Buyer Name
- (viii) Buyer Destination
- (ix) Product (Species / Grade)
- (x) Estimated net weight
- (xi) Logging Contractor
- (xii) Log Grader Number
- (xiii) Cartage Contractor
- (xiv) Truck Registration and Trailer Type
- (xv) Driver Signature

14.9 Recording Timber Resource – Load Dispatch Records (Secondary System)

In an instance where electronic data capture has failed, residual log deliveries will be accounted for in the majority of instances by load dispatch records issued by VicForests.

- (a) VicForests will supply books of load dispatch records to contractors (or their agents) at no cost from local VicForests' offices.
- (b) A Contractor must ensure that:
 - (i) load dispatch records (unused and used) are kept secure; and
 - (ii) load dispatch records remain at coupe landings; and
 - (iii) each load dispatch record will have its corresponding unique identifier number listed adjacent to the barcode; and
 - (iv) load dispatch records are used in sequence; and
 - (v) load dispatch records with unidentifiable patterns are returned to VicForests for replacement; and
 - (vi) load dispatch records must only be used for the destination and product for which they were printed.
- (c) Load dispatch record information requirements must be completed prior to removing the barcode. Information fields required one or both of the Load Dispatch Record or barcode are:
 - Date (Load Dispatch Record and barcode)
 - Time (Load Dispatch Record and barcode)
 - Haul Contractor
 - Truck Registration and Trailer Type (Load Dispatch Record and barcode)
 - Truck Scale Weight (Load Dispatch Record and barcode)
- (d) Load dispatch records which are damaged or replaced must:
 - Be marked 'CANCELLED'
 - Be marked with the number of the replacement load dispatch record
 - Secured and returned.
- (e) Load dispatch records must be returned with 7 days of book or coupe completion.
- (f) Used barcodes should be attached to the weighbridge record, where possible.

14.10 Recording Timber Resource – Log Tags

- (a) For measured sales log tags are be used to number individual logs. Where this is the case, log tags will be issued by VicForests or in a form approved by VicForests.

- (b) A Contractor must ensure that:
 - (i) log tags are kept secure and in good condition; and
 - (ii) log tags are used in sequence; and
 - (iii) a VicForests representative is notified if log tags are damaged or replaced.
 - (iv) All tags are attached to the end with at least 3 metal staples. (No Plastic staples are to be used at any time)

14.11 Synchronisation of Handheld Units

- (a) Handheld units are to be synchronised with VicForests Supply Chain Management System every 48 hours, or where not possible due to absence of 3G network coverage, at intervals agreed with the supervising Forester.

15. GRADING LOGS

15.1 Contractor Grading

- (a) A Contractor must ensure that:
 - (i) all sawlogs are prepared, graded and marked by an accredited grader using the hardwood log grading specifications shown in Schedule 9; and
 - (ii) other logs such as residual logs, are prepared according to specifications attached to relevant coupe plans, which may differ for specific customers; and
 - (iii) specifications for log grades are not changed, unless a local grading rule proforma is attached to the coupe plan; and
 - (iv) logs are graded from the butt first; and
 - (v) logs, as a general rule, are graded to maximise value; and
 - (vi) if an accredited grader is uncertain as to the grade of a borderline log or how to treat a longbutt, then:
 - that log must be set aside for inspection and grading by a VicForests representative; and
 - the VicForests representative will grade and mark the log with a VicForests' brand signifying that VicForests take responsibility for the grade of the log.

15.2 Contractor Hammers

- (a) A Contractor must ensure that:
 - (i) newly accredited Contractor graders pay a deposit of \$250 per hammer to a VicForests representative; and
 - (ii) hammers are not transferred from one person to another.

16. USING THE HARDWOOD LOG GRADING CARD

- (a) When using the hardwood grading card the following sequence of events should be used:
 - (i) Inspect the log for any limiting defect or feature that would immediately indicate the grades of the component sawlogs; then
 - (ii) Measure the DUB at each end of the log. Also measure the dimensions of any boxed defect that is present; then
 - (iii) Using the Hardwood Log Grading Card, determine the permitted number of defective quarters for each grade for the particular DUB and pipe combinations at each end of the log; then

- (iv) Check the permitted number of defective quarters in the first 2.7 m length of the log and determine the grade for that length; then
- (v) If the grade continues unchanged immediately after the first 2.7 m length, move along the log to the point where it is considered that the grade has changed, as determined by the number of defective quarters, SEDUB limitations, and estimated pipe diameter; then
- (vi) Check each end of the log to see if the presence of gum and shake affect the grade as determined above. If it does, downgrade the log accordingly; then
- (vii) Logs should be cross cut at any grade change points, unless the log is a multigrade log (sub-clause 17.2).

17. GRADING INTERPRETATIONS

17.1 Short Logs

The Contractor must ensure that:

- (a) if the short section occurs within a log between two sawlogs:
 - (i) for sections up to 1.2 m it can remain in the log for cartage convenience at the discretion of the VicForests' Customer. In this case the length should be added to the length of the lowest grade sawlog on either side; or
 - (ii) for sections greater than 1.2 m a sawlog of minimum length of the appropriate grade should be prepared but it may remain in the log for cartage convenience at the discretion of the VicForests' Customer.
- (b) if the short section occurs on the end of a log:
 - (i) for sections less than 1.2m the length may be trimmed as waste; or
 - (ii) for sections up to 1.2m it can remain on the log at the discretion of the VicForests' Customer. In this case the length of the section will be added to the length of the lowest grade sawlog in the log; or
 - (iii) for sections greater than 1.2m, but less than 2.7m a sawlog of minimum length of the appropriate grade may be prepared at the discretion of the VicForests' Customer; or
 - (iv) for sections greater than 1.2m but less than 2.7m where the VicForests' Customer does not wish to take this length it may be trimmed to waste.

17.2 Multigrading

The Contractor must ensure that:

- (a) at landings where logs are being dispatched to Customers accepting a range of log grades, log lengths containing more than one grade are permitted for cartage convenience, provided:
 - (i) grade lengths are clearly identified and recorded in accordance with sub-clause 14.4; and
 - (ii) each section of a multigraded log are a minimum of 2.7m in length; and
 - (iii) the multigraded log must include a 0.1m allowance for cross cutting by the customer.
- (iv) The extent of the pipe should be marked on the face of the Log

17.3 Using pipe and defect quarter allowances

The Contractor must ensure that:

- (a) boxing and defect quarters are used where they increase the grade of logs; and
- (b) boxes are measured around the centre of the log (diagram 1) in the following way:
 - (i) measure two diameters at 90 degrees to each other; then

- (ii) calculate the average of these diameters to determine the pipe defect to be used on the card; then
- (iii) convert rectangular boxes to a square of approximately equivalent area.
- (c) if the defect falls only in one quarter it should be treated as a defective quarter (diagram 1).

Diagram 1

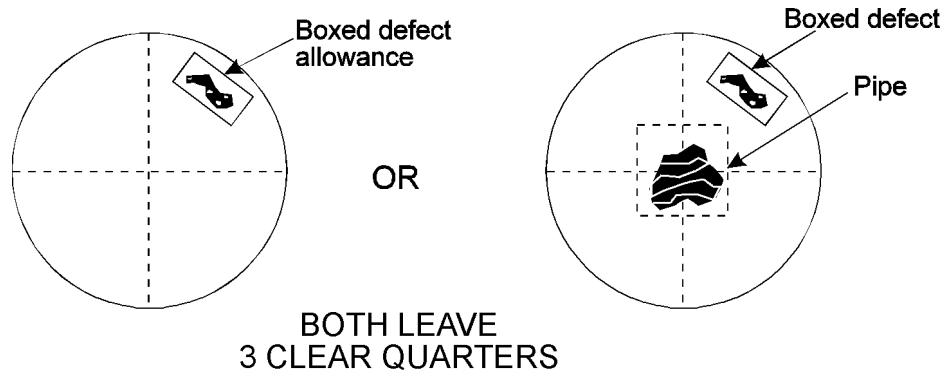

17.4 Gum Veins

- (a) A Contractor must consider the following three types of gum veins when grading logs:
 - (i) Tight gum veins less than 3mm in diameter are rings of ribbon or kino running between growth rings that have bridging wood tissue.
 - (ii) Tight gum veins more than 3mm in diameter are rings of ribbon or kino running between growth rings that have bridging wood tissue.
 - (iii) Loose Gum Veins are a ribbon of gum or kino between growth rings that are not joined by any wood tissue. They include gum pockets and shakes.
- (b) A Contractor must measure gum veins as follows:
 - (i) Gum veins are to be measured radially and calculated cumulatively;
 - (ii) Loose gum veins are to be measured first and checked against the card to determine the impact on grade;
 - (iii) Tight gum veins greater than 3mm are to be measured next. Add this length to the loose gum veins then check against the card to determine the impact on grade;
 - (iv) Tight gum veins less than 3mm are to be measured last. Add this length to the lengths of both the loose gum veins and tight gum veins greater than 3mm. Check this length against the card to determine the impact on grade.

17.5 Sloping Grain Interpretation

- (a) A Contractor must consider the following points when measuring sloping grain:
 - (i) Sloping grain is when the grain of the log does not run parallel but angles across the length of a log (Diagram 2).
 - (ii) To check sloping grain, measure the distance 'S' over a 2.7m length and compare it to the longitudinal length as shown. If the ratios below are exceeded, then the log should be downgraded appropriately:
 - B Grade 1:10
 - C Grade 1:8
 - D Grade 1:8

Diagram 2

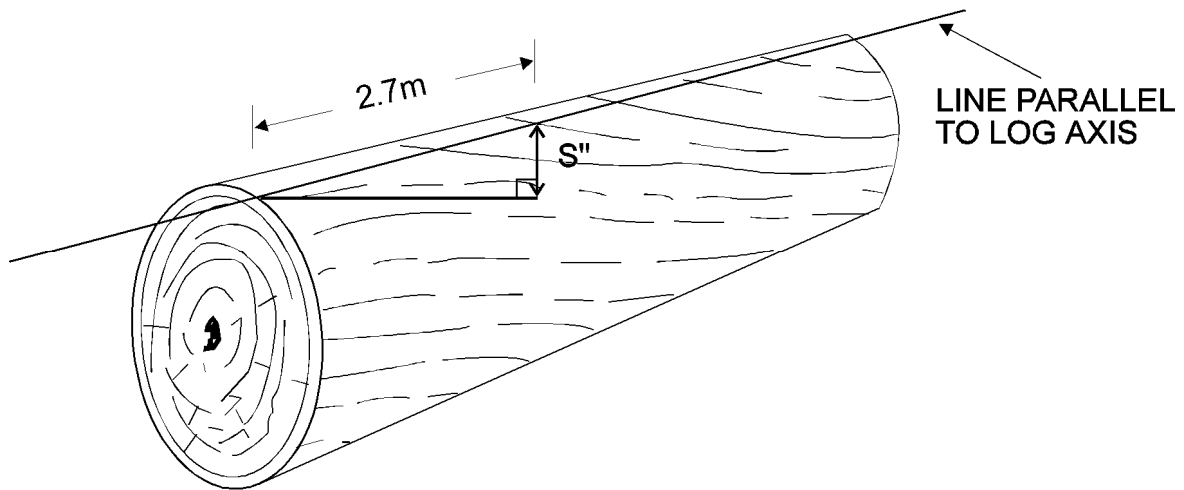

17.6 Stem Defect

- (a) A Contractor must consider the following points when measuring stem defect:
- (i) Stem defect is a defect extending into the heartwood which significantly reduces the recovery of sawn timber of the lowest merchantable grade; and
 - (ii) Stem defect will only be treated as a defect when the width of the defect extends into the heartwood greater than one third of a quarter.

17.7 Mechanical damage

- (a) Mechanical damage should be minimised through appropriate handling of logs on the landing and removal of damaged sections at the landing when appropriate.
- (i) Excessive waste will be identified and treated as a performance management issue
- (b) A Contractor must consider the following points when treating slabbing or splitting due to machine damage:
- (i) Where identified, slabbing and splitting is not to be considered as a defect; and
 - (ii) A log with a split or slab that covers more than 15% of the log end and runs for more than 30 cm into the log may have a volume reduction applied upon review by a VicForests representative. A log will be deemed to have 15% of the end affected by the slab or split, if the damaged section exceeds one fifth or 20% of the log diameter.
- (c) A Contractor must identify and treat the following forms of machine damage as a defect:
- (i) Stumped and shattered wood
 - Stumped and shattered wood must be removed from the log on the landing prior to final grading and delivery.
 - The delivery of stumped or shattered wood is unacceptable and should be dealt with in the mill if discovered by culling the affected portion of the log and remeasuring the remaining section.
 - (ii) Pulled wood that extends for more than 30 cm

17.8 Stain

- (a) A Contractor must consider the following points when assessing stain:
- (i) Stain can be defined as light or dark stain; and
 - (ii) Light stain has no impact on log quality; and

- (iii) Dark stain is defined as sawn timber that will not be suitable for appearance grade timber due to discolouration.

17.9 Sweep

- (a) A Contractor must consider the following point when grading sawlogs:
 - (i) No timber may have a sweep or crook which is greater than one-fifth of the diameter of that timber at the apex of the sweep or crook, measured from a straight edge inside the sweep or crook of at least 2.4 metres.

17.10 Ambrosia

- (a) A Contractor must consider the following points when measuring Ambrosia:
 - (i) Ambrosia is a beetle that leaves small borer holes that are generally associated with dark stain; and
 - (ii) Logs should only be downgraded from a B grade, if the Ambrosia cannot be boxed or quartered out and runs the length of the log.

17.11 Black Fleck

- (a) A Contractor must consider the following points when measuring Black Fleck:
 - (i) Black Fleck appears as fine black lines radiating out from the centre of a log; and
 - (ii) Logs will only be downgraded from a B grade, if the Black Fleck cannot be boxed or quartered out and runs the length of the log.

17.12 Long Butting

- (a) If a long butt is required, a Contractor must use the following procedure to maximise the recovery of D+ sawlog:

Diagram 3

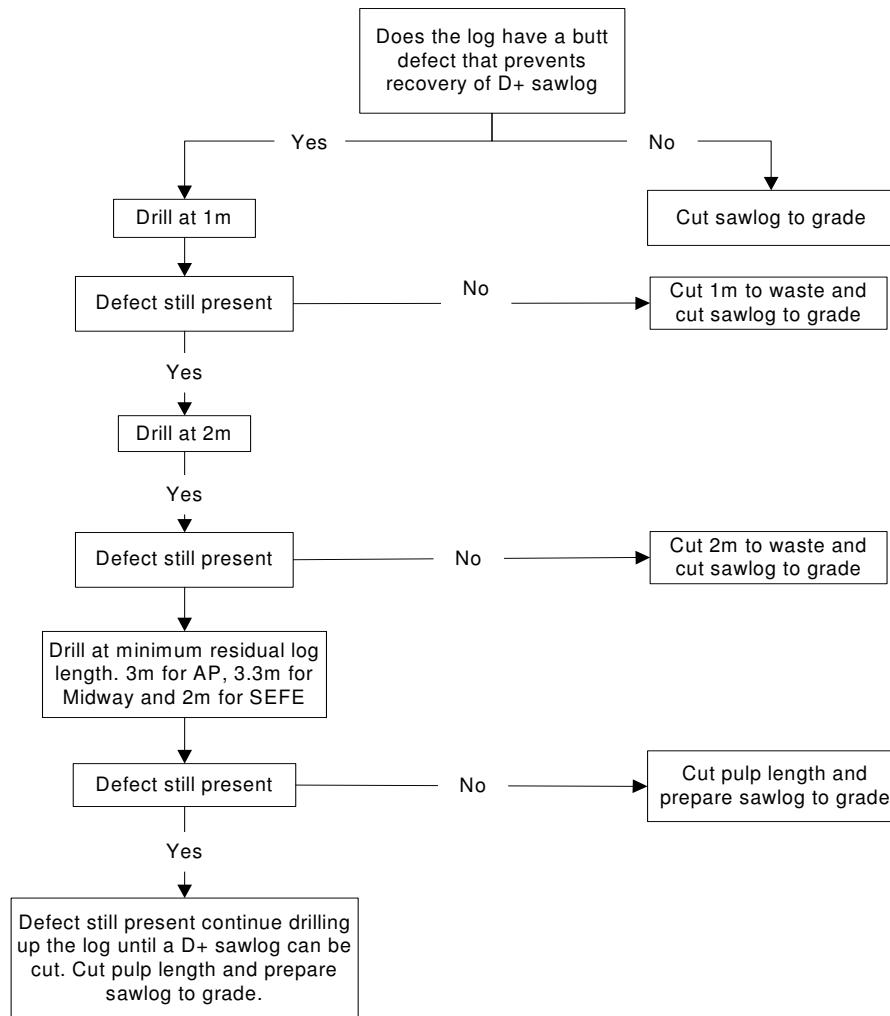

18. OFF SPECIFICATION TIMBER

18.1 General Disputes

- (a) If a log is branded with a VicForests brand and then found to be incorrectly graded, VicForests will take responsibility for any costs associated with the change in grade.
- (b) Where log presentation is found to be unacceptable to the Customer, VicForests may request the contractor to complete log presentation to an acceptable standard at the mill.

18.2 Machine Damage

- (a) A VicForests representative completing a Log Feedback Docket who determines that a machine damaged section should be deducted from the harvesting contractor's payment will mark the top of the docket in clear letters DEDUCT. Cases where the volume may not be deducted include:
 - (i) logs produced during a coupe set up process where there is no clear face to fall on; or
 - (ii) logs that have a specific local grading rule relating to natural splitting; or
 - (iii) logs from an unusually steep or rocky section of a coupe that a contractor has been asked to cut and prepare.

- (b) If mechanical damage which is out of specification involving slabbing or splitting is detected then the volume must be recalculated. The method for the volume calculation is to:-
- (i) Measure a 2.7 m length or the length of the slabbed section, whichever is longer (note if the log is <5.4 m long the entire length must be used as it cannot be cut into two logs).
 - (ii) At the mid point of this section measure the diameter from the edge of the split, around the log and to the centre of the split (see diagram 4). If the slabbed section remains attached to the log then an estimate will need to be made.
 - (iii) The volume of the log is determined using the standard log volume table using the length determined in (i) above and the diameter determined in (ii) above.
 - (iv) Any undamaged log section needs to be remeasured consistent with sub clause 14.5.

18.3 Measurement Half Logs

- (i) The log must be at least a minimum of 2.7m long
- (ii) At the mid point of this section measure the diameter from the edge of the split, around the log and to the centre of the split (see diagram 4).
- (iii) The volume of the log is determined using the standard log volume table using the length determined in (i) above and the diameter determined in (ii) above

Diagram 4 - Diameter Measurement of the Mechanical Damaged Section of the Log or half log

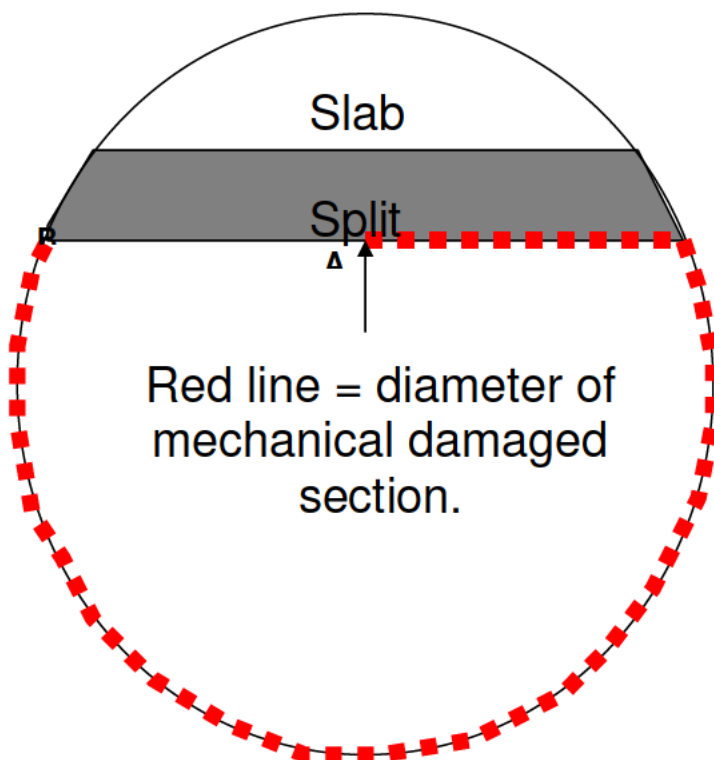

18.4 Local Grading Rules

From time to time VicForests may implement Local grading rules which will be specific to a coupe. Local grading rules will override normal grading rules.

19. CARTING LOGS

19.1 General Obligations of Driver

- (a) A truck driver operating within a State forest for the purposes of carting timber resource must:
- (i) hold a current, valid Timber Harvesting Operator's Licence; and
 - (ii) comply with any direction of a VicForests representative concerning:
 - the destination of any load; and
 - the sampling and checking of any load; and
 - any other relevant matter; and
- (b) A truck driver must:
- (i) comply with the *Road Safety (Vehicles) Regulations* 1999, including prescribed road load limits, when travelling on any public road; and
 - (ii) comply with any requirements of the Forest Coupe Plan about cartage routes; and
 - (iii) comply with any VicRoads permit conditions; and
 - (iv) comply with the directions of the LTL when working in an active coupe; and
 - (v) comply with the directions of the Log Storage Site Operator when working in a Log Storage Site; and
 - (vi) not cart timber resource on any road which is temporarily or permanently closed; and
 - (vii) comply with all relevant codes of conduct and relevant legislation; and
 - (viii) ensure that any material which falls, or is removed from the driver's truck is not left on a road, track or in a table drain, unless a VicForests representative directs otherwise; and
 - (ix) ensure they are inducted into all customer sites and that their induction status is current
 - (x) comply with any reasonable direction, by a customer, in relation to OH&S on a delivery site; and
 - (xi) observe both the Customer's normal safety and operational procedures and the Occupational Health and Safety Act; and
 - (xii) cause as little harm and inconvenience as possible at the delivery site; and
 - (xiii) not stay on the delivery site for any longer than is reasonably necessary; and
 - (xiv) take reasonable care not to cause loss or damage to property or injury on the delivery site; and
 - (xv) cooperate as much as possible with the Customer.
- (c) A truck driver must ensure that no load of timber resource which is to be brought to account by one method (for example, by weight) contains timber resource to be brought to account by another method (for example, by volume) unless:
- (i) two delivery dockets are used; and
 - (ii) a system is in place to clearly link the two dockets together.
- (d) A truck driver must ensure that each load and Customer / destination has a separate delivery docket.
- (e) A truck driver must ensure that all incidents and near misses at customer sites are reported to the customer and VicForests in line with reporting requirements outlined in section 7.3. (including faulty unloading equipment).
- (f) A truck driver must:
- (i) ensure that, once timber resource has been loaded on a truck, it is not removed until it is unloaded at the destination authorised by a VicForests representative; and

- (ii) ensure that a delivery docket concerning timber resource is not altered, once that timber resource is loaded onto the driver's truck, unless a VicForests representative has authorised the alteration; and
- (iii) confirm that the details specified in the delivery docket are correct (including time or loading and delivery), before driving the relevant load of timber resource away from a coupe or Log Storage Site by signing the delivery docket; and
- (iv) carry both:
 - the original copy; and
 - the VicForests customer's copy,
 of a completed delivery docket with the relevant timber resource to its destination unless otherwise directed by a VicForests representative and recorded in the coupe diary; and
- (v) ensure that a representative of the Customer signs the original docket or receipt of the load of timber resource; and
- (vi) after delivering a load of timber resource, leave both copies of the relevant delivery docket at a place designated by a VicForests representative.

19.2 Authorised Hours

- (a) A Contractor must not cart, or permit any other person to cart timber resource in a State forest, without the prior written permission from DEPI during the following times:
 - (i) after sunset and before the following sunrise on Monday to Saturday; and
 - (ii) at any time between midnight on a Saturday and midnight on Sunday.
- (b) A Contractor may apply for permission to cart timber resource from State forest within the times in 19.2 (a) by means of the following process:
 - (i) Advise the VicForests representative of the requirement to cart within the times in 19.2 (a);
 - (ii) The VicForests representative will lodge an Approval Request Form with DEPI detailing:
 - destination of produce;
 - all roads that will be used for carting (excluding temporary roads); and
 - when the cartage will occur.
 - (iii) The VicForests representative to advise the Contractor of the outcome.

19.3 Suspension of Cartage

- (a) A VicForests representative may temporarily suspend cartage on any road in a State forest:
 - (i) during wet weather in accordance with clause 21; or
 - (ii) during extremely dry weather;

19.4 Checking Loads

- (a) A VicForests representative may check and, if the VicForests representative considers it necessary, correct the marking and measuring of any log loaded on any truck and any delivery docket (or other document which the VicForests representative requires to be accurately completed) relating to the load on that truck at:
 - (i) any coupe or Log Storage Site where timber resource is loaded; and
 - (ii) while the truck is travelling to its destination; and
 - (iii) after the truck arrives at its destination.

20. LOG STORAGE SITES

20.1 Log Storage Site Plans

- (a) where VicForests establishes a Log Storage Site to facilitate efficient haulage operations, a Log Storage Site Plan will be prepared and issued to a Log Storage Site Operator.
- (b) the Log Storage Site Plan will address road and storage area construction and maintenance, drainage, safe operations, log organisation, rehabilitation and fire protection.

20.2 Log Storage Site Operators

- (a) the Log Storage Site Operator must comply with obligations outlined in sub-clause 3.3. and any agreement with VicForests.

20.3 Transit Log Storage Sites

- (a) the use of Transit Log Storage Sites, either located in State forest or on private property requires the approval of a VicForests representative.
- (b) a Log Storage Site Plan is required in accordance with 20.1
- (c) a maximum of 1000 tonnes of Pulplog and E grade Sawlog is to be stored at any time unless otherwise authorised by a VicForests Representative.
- (d) logs may be held for a maximum period of four weeks unless otherwise authorised by a VicForests Representative.
- (e) log piles must be clearly segregated by grade and contractor.
- (f) haulage rates for deliveries via a transit log storage sites will be calculated on the basis of the distance between the original coupe and the scheduled delivery site.

21. WEATHER RESTRICTIONS

- (a) A Contractor must suspend any commercial harvesting:
 - (i) during wet weather when, and for such period as, a VicForests representative directs; and
 - (ii) in a water supply catchment, as directed by the VicForests representative;
 - (iii) during times of high fire danger (as notified by a VicForests representative), in accordance with the *Forests (Fire Protection) Regulations 2004*; or
 - (iv) in any other area where, and for such period during which, the VicForests representative declares that there is a risk that commercial harvesting may have an adverse effect on water quality.
- (b) A Contractor must unless otherwise specified on the Forest Coupe Plan, temporarily suspend snigging, forwarding or loading logs whenever:
 - (i) soil in an area is saturated; or
 - (ii) water is flowing on or over any extraction or forwarding track; or
 - (iii) there is a reasonable risk that effective drainage of the extraction or forwarding track cannot be maintained; or
 - (iv) there is a reasonable risk that significant rutting may form in the extraction or forwarding track; and
- (c) A Contractor must stop any truck under the contractor's control from travelling in any part of a State forest when, and for such period as:
 - (i) There is a reasonable risk that movement of a truck may either:
 - lead to muddy water directly entering any stream or wetland; or

- disturb the surface materials of any road or track, leading to interference with the quality of any water; or
 - (ii) snow is lying on any road or track; or
 - (iii) water is flowing on the surface of any unsealed road or track; or
 - (iv) the movement of a truck will deposit mud on a gravelled or sealed road; or
 - (v) There is a reasonable risk of damage to the structure of any road, which may reduce its load-bearing capacity; or
 - (vi) an Authorised DEPI Officer closes a road or track; or
 - (vii) a truck is unable to move without assistance; or
 - (viii) the surface material on any road has unravelled and, in there is a reasonable risk to the quality of water in any stream or wetland; or
 - (ix) an Authorised DEPI Officer directs.
- (d) A Contractor must ensure that no vehicle or machine is used to assist another vehicle to start moving in wet weather, without the prior approval of a VicForests representative being noted on the Forest Coupe Plan, except on or in the immediate vicinity of, a log landing.

22. FIRE PROTECTION

22.1 Access for Fire Suppression

A Contractor must:

- (a) within a coupe, maintain all pre-existing roads and tracks in serviceable condition for fire suppression, throughout commercial harvesting.

22.2 Fire Fighting

- (a) Any Contractor who starts or detects a fire must:
 - (i) report it immediately to a VicForests representative; and
 - (ii) report it immediately to an Authorised DEPI Officer or ring 000; and
 - (iii) take appropriate action to prevent the fire from spreading.
- (b) A Contractor must:
 - (i) take all reasonable precautions to:
 - prevent an outbreak of fire; and
 - suppress any fire;
 - (ii) at the direction of an Authorised DEPI Officer:
 - make available any appropriately accredited personnel employed and any plant or equipment owned, by the Contractor; and
 - release and make available any person and their plant or equipment contracted or sub-contracted by the Contractor,

22.3 Fire Fighting Equipment

A Logging Team Leader must ensure that the following equipment is available at the coupe during any commercial harvesting which occurs between 1 November and 30 April in any year:

- (a) 1 rakehoe for each member of the Logging Team, located at the log landing closest to the Team; and
- (b) Not less than a minimum of 400 litres of water with a pressure pump, trailer or tank that is robust and can be moved to suppress a fire without much difficulty

- (c) at least one powder-type stored pressure fire extinguisher of not less than 4.5 kilogram total capacity ABE for each item of plant used at the coupe; and
- (d) at least one powder-type stored pressure fire extinguisher of not less than 1 kilogram total capacity ABE for each vehicle less than 3 tonnes GVM used at the coupe.
- (e) The vehicle pulling the fuel trailer must be equipped with one powder-type stored pressure fire extinguisher of not less than 4.5 kg total capacity
- (f) For every logging truck
 - (i) at least one powder-type stored pressure fire extinguisher of not less than 4.5 kilogram total capacity ABE

22.4 Fire Precautions

- (a) A Contractor must ensure that:
 - (i) an area of at least 3 metres from the outer perimeter of any tent, hut, caravan or other structure at a camp site is kept clear of any flammable material (except standing green trees); and
 - (ii) a fire break at least 3 metres wide is constructed in any area where in a VicForests representative's opinion there is a risk that metal parts moving during cable harvesting may cause sparks.
- (b) Every Licensed Timber Harvesting Operator who operates mechanical equipment within State forest must:
 - (i) stay with the equipment for at least 5 minutes after the equipment is shut down or turned off; and
 - (ii) after that time, inspect the equipment for any defect which may create a risk of fire, before leaving the equipment.
- (c) A Contractor must ensure that:
 - (i) all felling, snigging and processing must be suspended as directed by a VicForests representative on days of Very High to Code Red fire danger; and
 - (ii) any conditions specified by a VicForests representative are followed.

23. STORING AND USING FUEL AND SERVICING MACHINERY

23.1 Location

- (a) Subject to paragraph (b), a Contractor may establish a fuel and oil store or a site for servicing machinery at a location approved by a VicForests representative.
- (b) A fuel and oil store or a site for servicing machinery must not be located:
 - (i) in any excluded area; or
 - (ii) less than 40 metres from any stream, wetland or drainage line.

23.2 Precautions

- (a) Unless the Forest Coupe Plan specifies otherwise, a Contractor must ensure:
 - (i) that any area where fuel or oil is stored is properly bunded; and
 - (ii) machinery is only serviced over drip trays or other appropriate methods of containment are employed; and
 - (iii) that the construction, maintenance and operation of each fuel and oil store or site for servicing machinery complies with the *Dangerous Goods Act 1985* and the *Dangerous Goods (Storage and Handling) Regulations 2000*.
 - (iv) All containers of fuel, oil and chemicals greater than 10L must be stored within a properly bunded area; and
- (b) Bunding by Contractors will be considered adequate if:

- (i) bund walls are constructed around fuel and oil storage areas such that the volume of containment in the event of spillage is at least 1.2 times the volume of the store.
- (c) Portable bunds may be required where Contractors are working with drums or equipment that may cause contamination in areas where earth bunds are not practical.



23.3 Spills

A Contractor must ensure that:

- (a) no fuel, oil or chemical is spilt anywhere within a coupe; and
- (b) land and water within a coupe is not polluted by any fuel, oil or chemical; and
- (c) if fuel, oil or chemical is spilt anywhere within a coupe:
 - (i) immediate action is taken to control that spill; and
 - (ii) every effort is promptly made to clean up the fuel or oil and any material affected by the spill; and
 - (iii) the VicForests representative is informed as soon as possible; and
 - (iv) the site where the spill occurred is cleaned up and material affected by the spill is disposed of, in the manner directed by a VicForests representative.

23.4 Disposing of waste

A Contractor must ensure that:

- (a) no drums, rubbish, waste or litter accumulates at a fuel store or site for servicing machinery; and
- (b) any drums, rubbish, waste or litter at a fuel store or site for servicing machinery is removed from the State forest:
 - (i) whenever a VicForests representative so directs; and
 - (ii) before harvesting in the coupe is complete.

24. CAMP SITES, WASTE DISPOSAL AND FOREST HYGIENE

24.1 Camp sites

- (a) Subject to paragraph (b), a Contractor:
 - (i) may establish a camp site or shower unit at any place approved by a VicForests representative; and

- (ii) must install a lavatory of a type approved by a VicForests representative wherever a camp site or shower unit is established.
- (b) A camp site or shower unit must not be located:
 - (i) in any excluded area; or
 - (ii) less than 20 metres from any stream, wetland or drainage line.
- (c) A lavatory must not be located less than 100 metres from any stream or wetland.
- (d) Waste must not be disposed of in State forest.

24.2 **Disposing of Waste**

A Contractor must ensure that:

- (a) drums, rubbish, waste and litter:
 - (i) do not accumulate in a coupe; or
 - (ii) are not burnt, dumped or left anywhere within State forest; and
- (b) rubbish stored in appropriate containers is removed from State forest:
 - (i) whenever a VicForests representative so directs; and
 - (ii) before harvesting in the coupe is complete ; and
- (c) a camp site is kept clear of rubbish or other waste or litter at all times; and
- (d) a camp site is rehabilitated to the VicForests representative's satisfaction, promptly when the Contractor stops using it.

24.3 **Water Points**

- (a) A Contractor must ensure that any damage caused by a Contractor to any structure, or any access to, a water point is promptly:
 - (i) reported to a VicForests representative; and
 - (ii) repaired to a VicForests representative's satisfaction.

24.4 **Forest Hygiene**

A Contractor must ensure that:

- (a) The Contractor's machinery, vehicles and other equipment do not transport any pest-animal, pest-plant or disease:
 - (i) into or from a State forest; or
 - (ii) from one place to another, within a State forest; and
- (b) any direction by a VicForests representative about taking precautions or action to prevent any pest-animal, pest-plant or disease from being transported, contrary to paragraph (a), is obeyed. This may require wash down of machines to remove soil and plant material before the machinery leaves the current site.

24.5 **Selecting a Field Washdown Site for Machinery**

- (a) Where required in 24.4 (b), a Contractor must ensure that consideration is given to the following points when selecting a washdown site:
 - (i) Choose a site which slopes away from a susceptible area; and
 - (ii) Ensure run-off will not enter any watercourse or waterbody directly by using a buffer of at least 30m; and
 - (iii) Avoid sensitive vegetation or wildlife habitat eg remnant native vegetation and threatened species sites; and
 - (iv) Select mud-free sites (e.g. well grassed, gravel, bark or timber corded) which are gently sloped to drain effluent away from the washdown area; and
 - (v) Allow adequate space to move tracked vehicles; and

- (vi) Where there will be large quantities of effluent or there is a risk of extensive run-off, the washdown area should be bunded and a sump constructed to safely dispose of the effluent. Particular care where the effluent is likely to be contaminated with oils is to be taken.

24.6 **General Washdown Procedure for Machinery**

- (a) Unless a VicForests representative specifies otherwise, where required in 24.4 (b), a Contractor must use the following procedure when washing down machinery:
 - (i) Select a washdown site and prepare the surface or construct bunding as required; and
 - (ii) Safely park the vehicle free of any hazards (e.g. electrical), ensure the engine is off and the vehicle is immobilised; and
 - (iii) Look over the vehicle, inside and out, for where dirt and plant material, including seeds are lodged. Pay attention to the underside, radiators, spare tyres, foot wells and bumper bars; and
 - (iv) Remove any guards, covers or plates if required being careful of any parts that may cause injury; and
 - (v) Knock off large clods of mud, use a crow bar if required and sweep out the cabin; and
 - (vi) Use a vacuum or compressed air where available for removing dried plant material like weed seeds and chaff in radiators and other small spaces where this material lodges. Brush off dry material if no other facilities are available; and
 - (vii) Clean down with a high pressure hose and stiff brush/crowbar. Use only freshwater if washing down in the field; and
 - (viii) Start with the underside of the vehicle, wheel arches, wheels (including spare). Next do the sides, radiator, tray, bumper bars etc and finally upper body. Some vehicles may need to be moved during washdown eg tracked machinery; and
 - (ix) Clean any associated implements, eg buckets; and
 - (x) Check there is no loose soil or plant material that could be readily dislodged or removed; and
 - (xi) In wash bays, steam treat or rinse off vehicle with clean water; and
 - (xii) Wash effluent away from vehicle, do not drive through wash effluent.

25. **COMPLETION OF COMMERCIAL HARVESTING**

25.1 **Restoration of roads, structures and works**

A Contractor must ensure that:

- (a) as soon as Commercial Harvesting is complete in a coupe, any damage (not attributable to fair wear and tear) caused during commercial harvesting by the Contractor to any road, structure, work or similar asset within the relevant State forest, is repaired to a VicForests representative's satisfaction.

25.2 **Coupe Completion**

- (a) Subject to paragraph (b), and unless otherwise authorised by a VicForests representative, a Contractor must not either abandon commercial harvesting in a coupe, or commence commercial harvesting in any other coupe, until:
 - (i) all commercial harvesting activities within the existing coupe have been completed; and

- (ii) all rehabilitation works required by the relevant coupe monitoring record (harvesting) and Forest Coupe Plan have been completed, and either;
 - (iii) a Final Clearance; or
 - (iv) a Provisional Clearance.
- has been signed by VicForests on the Forest Coupe Plan.
- (b) The contractor will be recalled if excess quantities of sawlog or residual logs remain on the coupe (see sub-clause 6.5), or if breaches to the Code or the environmental aspects of the Utilisation Procedures are identified by the VicForests representative and recorded on the coupe monitoring record (harvesting).
 - (c) A Contractor who is given a Provisional Clearance or is otherwise authorised by a VicForests representative under paragraph (a):
 - (i) may construct forward roads or log landings, or carry out other preparation at a new coupe, even though the person has not fully complied with the requirements of sub-paragraph 24.2(b)(ii), sub-clause 25.1 or paragraph 25.2(a); and
 - (ii) must, by a time specified in writing by a VicForests representative, fully comply with the requirements of sub-paragraph 24.2(b)(ii), sub-clause 25.1 and paragraph 25.2(a).
 - (d) A VicForests representative may require any Contractor who has not fully complied with the requirements of sub-paragraph 24.2(b)(ii), sub-clause 25.1 or paragraph 25.2(a) to do so, by a time specified in writing by the VicForests representative.

26. CONTRACTOR PERFORMANCE

26.1 Assessment of Contractor Performance

- (a) Key Performance Indicators (KPIs) allow the performance and quality of services to be assessed and enable VicForests to monitor success against business targets and obligations.
- (b) VicForests assesses contractor performance using a range of KPIs which may include but not be limited to the following:
 - (i) OH&S, with input from:
 - Coupe diary records; and
 - Third party audits; and
 - Incident reports; and
 - OHS contract breaches; and
 - Harvest OHS Coupe monitoring records (CMR); and
 - VicForests Haulage truck audits.
 - (ii) Environment, with input from:
 - Coupe diary records; and
 - Timber Harvesting Regulation breaches relayed to DEPI; and
 - Environmental contract breaches
 - Harvest Environment CMR.
 - (iii) Production, with input from:
 - Actual versus Plan by Month and Year To Date; and
 - Delivery schedule compliance and accuracy; and
 - Monthly Plan contract breaches; and
 - Harvest Utilisation CMR.

- (iv) Administration Quality, with input from:
 - Docket accuracy; and
 - Administration contract breaches; and
 - Code of Behaviour adherence; and
 - Haul truck overload reports; and
 - Haul fatigue management compliance; and
 - Haul Code of Conduct incident reports; and
 - Harvest Administration CMR.
- (v) Log Quality, with input from:
 - Harvest Log Grading CMR and
 - Off spec logs by customer; and
 - Product quality contract breaches.

26.2 Monthly Plans

- (a) A Contractor must inform VicForests as soon as it is apparent that indicative species and grade quantities in a Monthly Plan may not be achieved to allow for prompt variation of the Monthly Plan.

SCHEDULE 1

Recommended maximum distance in metres between cross drains for rehabilitation of extraction tracks and mineral earth boundary tracks

	General Slope ¹				
Soil Erosion Hazard	Less than 6°	6 - 11°	11 - 18°	18 - 27°	More than 27°
	Less than 1:10	1:10 - 1:15	1:5 – 1:3	1:3 – 1:2	More than 1:2
	Less than 10%	10 – 20%	20 - 33%	33 – 50%	More than 50%
	Distance (m)	Distance (m)	Distance (m)	Distance (m)	Distance (m)
Low	120	90	60	30	15
Medium	90	60	40	20	10
High	60	30	20	10	NP*

* NP = grade not permitted.

The General Slope is an estimate of the general land slope and track slope.

SCHEDULE 2

Design Standard Guidelines for Roads*

Road Classification	5C (minor road)			5D (access track/road)			5E (access track)		
	Flat	Rolling	M'tain	Flat	Rolling	M'tain	Flat	Rolling	M'tain
Terrain Type									
Main Geometric Characteristic									
Speed value km/hr	60	40	20	40	30	< 20	N/A	N/A	N/A
Cross section elements									
number of traffic lanes	1	1	1	1	1	1	1	1	1
minimum cross fall/camber %	5	5	5	5	5	5	4	4	4
maximum superelevation %	6	8	10	6	8	10	N/A	N/A	N/A
minimum traffic lane width m	3	3	3	3	3	3	3	3	3
minimum shoulder widths m	1.5	1	0.5	1	0.5	0.5	0	0	0
minimum carriageway width (lanes + shoulder) m	6	5	4	5	4	4	3	3	3
minimum formation width (including verges)	8	7	6	7	6	6	3	3	3
Table drain width	0.6	0.6	0.6	0.6	0.6	0.6	N/A	N/A	N/A
Horizontal Geometry									
minimum radius curve m	170	160	15	70	35	15	N/A	N/A	N/A
**minimum stopping sight distance m	90	50	30	50	30	20	N/A	N/A	N/A
***minimum meeting sight distance m	180	100	60	100	60	40	N/A	N/A	N/A
Vertical Geometry									
maximum vertical grade %	6	8	12	6	8	15	N/A	N/A	N/A
Maximum excess vertical grade %	20	20	20	20	20	20	N/A	N/A	N/A
Maximum distance of excess grade	100	100	100	100	100	100	N/A	N/A	N/A

* Adapted from the Review of Road Classifications, Geometric Designs and Maintenance Standards (ARRB 2001)

** Distance required for a vehicle to stop in time to avoid hitting a fixed object on the road.

*** The distance required for two vehicles approaching each other to stop before colliding.

**** Traffic lane width must be increased on corners up to a maximum of 7.5m on 15m radius corners to allow for B Double trailer configurations.

SCHEDULE 3

Maximum Clearing Widths (m) required for Typical Road Construction

Side	Slope	Road Class			
(degrees)	(%)	5B	5C	5D	5E
0-7.5	0-13	13	7	6	4
7.5-15	13-27	17	11	10	7
15-22.5	27-41	23	17	16	10
22.5-30	41-58	30	24	23	14

Notes

- Recommended clearing width is a horizontal distance.
- Table assumes that debris disposal is complete before construction commences.
- Extra clearing width may be required if debris disposed is concurrent with road construction.
- Clearing widths do not include slashed verges except within engineering or road safety priority areas where extra cleared widths are shown to be required.
- Recommend clearing width for temporary road is 6m.
- Additional widening is often required at curves.

SCHEDULE 4

Maximum distances in metres between road run-offs, cross drains and culverts on roads

			Road	Grade				
Soil	1:50	1:25	1:15	1:12	1:10	1:8	1:7	1:5
Erosion	1°	2°	3.5°	4.5°	6°	7°	8°	11°
Hazard	2%	4%	6%	8%	10%	12%	15%	20%
Low	250	170	130	115	100	90	60	30
Mod	200	150	120	105	90	80	50	NP*
High	160	130	110	95	80	65	NP*	NP*

* NP = Road grade not permitted

SCHEDULE 5

Minimum Number of Habitat Trees

FMA/ FMP	Forest Type	Habitat Tree Prescriptions*	Guide to Selecting and Distributing Habitat Trees
East Gippsland	All	4 – 5 trees per ha	<ul style="list-style-type: none"> Habitat trees should be old living trees with a range of hollow sizes. Where these are absent or not present in sufficient numbers, trees that are old enough to develop hollows during the next 50 years may be used. Stags and younger, smaller trees may be included as habitat trees if trees in dot point 1 are absent or not present in sufficient numbers.
Tambo	Ash/HEMS	4 – 5 trees per ha	<ul style="list-style-type: none"> Habitat trees should preferably be retained in small clusters, which include younger regrowth and understorey. Clusters must be spaced across the coupe. Habitat tree selection must consider the following: the species and likely density of hollow-dependent wildlife inhabiting the area; the density and arrangements of habitat trees may vary with EVC; and the proximity of other retained vegetation.
	Mixed Species	4 – 5 trees per ha	<ul style="list-style-type: none"> Seed trees should be counted towards habitat tree numbers.
<p>Note: In coupes adjacent to Brown Mountain Creek (in the area bounded by E655004 and N5873083 in the south-western corner and E657978 and N5876371 in the north eastern corner (GDA1994 and coordinate system VICGRID)): DEPI staff with appropriate expertise in biodiversity management will guide the identification of hollow bearing habitat trees. This will be done in consultation with VicForests and the harvesting contractor(s); all trees with DBHOB over 250cm will be retained where safe to do so; where present in sufficient numbers and it is safe to do so, at least 5 hollow bearing habitat trees per ha will be retained (trees greater than 250cm may count towards this); where more than 6 retained hollow bearing habitat trees are present in a concentrated area (less than one quarter of a ha) then harvesting machinery should minimise traffic in that area; harvesting debris and other fuels are to be removed from within 20m of the base of retained hollow bearing habitat trees or groups of retained hollow bearing habitat trees.</p>			
Central Gippsland (other than Central Highlands FMP area)	All	4 – 5 trees per ha	<ul style="list-style-type: none"> Tree hollows tend to occur in mature, senescent and dead trees. For the majority of eucalypts in Gippsland, hollows suitable for nesting and roosting begin to form in trees over 100 years old. Some State forest areas of Gippsland have been utilised for timber harvesting for over 100 years and the remaining hollow-bearing trees are fewer than would be found in undisturbed forest. For this reason, the larger trees should generally be favoured for retention as habitat trees. Seed trees should be counted towards habitat tree numbers.

Central Highlands (Central, Dandenong and part of Central Gippsland).	Ash/HEMS	All ash eucalypts originating before 1900 40+ trees per 10 ha for trees originating from 1900 onwards	<ul style="list-style-type: none"> Habitat trees should be old living trees with a range of hollow sizes. Where these are absent or not present in sufficient numbers, trees that are old enough to develop hollows during the next 50 years may be used. In mixed-species forest retained trees should remain scattered across the timber harvesting coupe Potential hollow-bearing ash eucalypts should be retained in clumps to increase their protection from exposure, windthrow and fire Within 150-m of retained vegetation there is no requirement to retain potential hollow-bearing trees (although at least 40 trees per 10 hectares should be retained across the coupe) Trees should be retained where they can be most easily protected from damage during harvesting and site preparation treatment. Seed trees should be counted towards habitat tree numbers.
	Mixed Species	40+ trees per 10 ha	
Benalla / Mansfield	Ash/HEMS	4 – 5 trees per ha	<ul style="list-style-type: none"> Retained trees must include live hollow bearing trees where they exist, and trees of younger age classes likely to develop hollows in the longer term. Where possible dead trees must be retained in addition to live trees. Habitat trees must generally be retained adjacent to areas of high value habitat and to areas most easily protected from damage during harvesting and subsequent management operations. Habitat trees may be grouped but groups must be dispersed across the coupe. Seed trees should be counted towards habitat tree numbers.
	Mixed Species	4 – 5 trees per ha	
North East (Wangaratta and Wodonga)	Ash/HEMS	4 – 5 trees per ha	<ul style="list-style-type: none"> Habitat trees must generally be retained adjacent to areas of high value habitat and to areas most easily protected from damage during harvesting and subsequent management operations. Habitat trees may be grouped but groups must be dispersed across the coupe. Seed trees should be counted towards habitat tree numbers.
	Mixed Species	4 – 5 trees per ha	

* In all cases habitat tree retention rates apply to the net logged area. The net logged area is the gross coupe area, less areas specifically excluded from harvesting by legislation, the *Code*, management plans or prescriptions. Streamside buffers, rainforest buffers, and Heritage River Areas should therefore not be regarded as part of the net logged area. Large and readily identifiable areas that are generally excluded by the *Code* etc. should also not be counted as part of the net logged area (eg. large, contiguous areas of >30° slope). Smaller such areas that are not readily defined until harvesting begins (eg small rocky areas, small areas of steep slope, inaccessible areas) may be left unharvested by the VicForests representative and counted as retained habitat within the net logged area. Similarly, decisions to extend the length or width of streamside reserves beyond the minimum requirements of the *Code*, or to retain trees in filter strips, should be included as part of the net logged area and counted towards habitat prescriptions.

SCHEDULE 6

Guide to Selecting Seed Trees

For seed tree coupes, it is preferable to select healthy, well-formed trees as seed trees where seed crop monitoring has indicated that there will be sufficient seed for regeneration. It is also preferable to select healthy trees for health and safety reasons, to limit hazardous trees on the site. However, trees that are damaged or of poor form due to environmental reasons such as fire, lightning or wind damage, may be chosen if they are genetically satisfactory. If possible, avoid trees exhibiting obvious spiral grain, multiple leaders, and heavy lower branching, as these traits are often inherited.

The Code of Practice for Timber Production 2007 requires the natural floristic composition and representative gene pools to be maintained when regenerating native forests by using appropriate seed sources and mixes of dominant species.

Trees retained for habitat, landscape values, or stream protection may also serve as seed trees. The contribution of edge trees should also be allowed for, by not marking seed trees within about 1 x tree height of a coupe edge compromising mature trees.

SCHEDULE 7

Cording and Matting Prescriptions

Cording	means log material, eucalypt and non-eucalypt, with a diameter greater than 15cm that is placed in a corduroy fashion on landings and snig tracks to distribute machine loading over a larger area thus reducing soil compaction. It also separates machine tracks / wheels from the soil surface reducing the capacity for rutting to occur;
Matting	is the smaller head material (branches), bark or other vegetation that is used to cover cording on snig tracks and landings;

1 General

1.2 The selection and design of coupes to be corded and matted should be carried out by the VicForests representative and the harvesting contractor well in advance of the actual harvesting. (Note: The average maximum coupe slope that is feasible for cording and matting operations is about 12°. Minor side cutting may be required on slopes about 8°).

1.2 The area of the coupe to be subject to cording and matting must be delineated in the Forest Coupe Plan. Any variations must be:

- o authorised by the supervising VicForests representative, and
- o clearly documented in the coupe diary and notated on the Forest Coupe Plan.

No operation is to proceed while wet weather poses an unacceptable risk to general soil condition or water quality.

2 Cording and Matting

2.1 Sawlogs are not to be used for cording. Residual logs may be used when no suitable alternative material is available. Where possible, cording is to be salvaged for utilisation as residual material.

2.2 Where designated on the Forest Coupe Plan, trees that are bearing moderate to heavy seed crops are not to be used for cording or matting until after the capsules have been collected from them. Until then, the heads are to be placed so as to protect them from harvesting operations.

3 Landings

3.1 Landing construction and coupe access road construction must be undertaken while ground conditions are dry enough for conventional operations, unless authorised by the VicForests representative.

3.2 Rock is not to be utilised on landings (or snig tracks). The use of rock is to be restricted to access roads and loading bays.

3.3 Trees larger than 25cm in diameter on the proposed landing must be felled rather than pushed out of the ground, to minimise soil disturbance.

3.4 There is no requirement to stockpile topsoil when cording can be placed directly onto the pre-existing ground surface.

3.5 If the soil profile has been significantly disturbed during landing construction then topsoil must be stockpiled, and the landing is to be rehabilitated as per conventional landing requirements.

3.6 During coupe operations the depth of matting on the landing must not exceed 30cm.

3.7 Landing rehabilitation: As much matting as possible should be removed from the landing and spread into the coupe. Then the cording is removed (preferably salvaged) and any excess bark and broken pieces of cording must be heaped and aerated to facilitate burning. There should be areas of receptive seedbed between the heaps. Ripping/cultivation will be required if machinery operations during removal or cording/matting have compacted the soil or if the landing was benched before being corded.

4 Snig Tracks

4.1 Snig (extraction) tracks are to be constructed in places and patterns to allow natural drainage of the coupe.

4.2 Snig tracks are to be corded prior to machinery disturbing the soil, to prevent rutting and to minimise soil compaction. Shovelling should not be carried out along snig tracks routes prior to them being corded and matted.

4.3 Some side cutting may be required in the construction of snig tracks on steeper country, but it should be minimised and confined to topsoil. Side cuts may only be constructed when the soil is dry enough and must be corded and matted prior to any snigging.

- 4.4 If a snig track breaches the Utilisation Procedures, the track is not to be used again until the cording and/or matting is repaired. In this event, no alternative track must be constructed.
- 4.5 Bark can only be used on snig tracks if it is placed on cording. This is to minimise bark mixing with the topsoil.
- 4.6 Only the harvesting machine and supporting excavator are permitted to operate off the corded and matted tracks or landings.
- 4.7 Turning around of machines on cording and/or matting on snig tracks is to be minimised. Where necessary, it is to be restricted to designated turning points.
- 4.8 Snig track rehabilitation: All cording and matting on snig tracks is to be lifted and aerated to facilitate burning. The majority of the material is to be kept on the track, to block any water flowing down the track, thus eliminating the need for cross draining.

5 Cartage

- 5.1 Cartage must not proceed if the structural integrity of the road is likely to be compromised, or if water is flowing along the road surface.
- 5.2 Cartage must not proceed if water is flowing past existing drainage structures, such as culverts or run-offs. This can compromise water quality.
- 5.3 Loading bays are to be maintained so as to prevent the transportation of mud or bark from the lading bay to the road. This will require proper drainage (including a drain between the edge of the landing and the loading bay) and an adequate depth and width of crushed rock. Where feasible, the bay should be corded or geo-textiled to prevent mud/soil mixing with the crushed rock.

6 General Harvesting

- 6.1 No live trees larger than 25cm in diameter are to be pushed over in the course of general coupe operations. They are to be felled and the stump cut as close to the ground as necessary. Cording and/or matting can then be placed directly over the stump. The only instance when larger live trees are permitted to be pushed is during access track construction or if side-cutting for snig track construction.
- 6.2 Shovelling of logs must not create ruts or channels which may carry water.
- 6.3 Care should be taken when snigging on hot dry days, as friction between logs and matting has the potential to start fires. The contractor must attempt to extinguish any such fire as soon as possible.
- 6.4 Bark must not be disposed of by piling along the edge of snig tracks. If bark is not required for matting, it is to be redistributed through the coupe by excavator, though it can initially be removed from the landing by skidder.
- 6.5 Large slash accumulations, including bark, are to be avoided where possible to provide for an even burn. In-coupe bark piles must not exceed 4m³, and all piles of bark must be placed at least 30m from the coupe boundary.
- 6.6 Coupe boundary trails are to be constructed by removing existing vegetation and harvesting slash to provide for a 3m break as close as is practicable to the coupe boundary. This is to be undertaken with an excavator. Any material removed is to be deposited within the general harvesting area.

SCHEDULE 8

Coupe Marking Standard Procedures

Feature	Tape Colour or other method of marking Central Highlands	Tape Colour or other method of marking East Gippsland	Tape Colour or other method of marking West Gippsland
Coupe boundary	Blue tape	Blue tape	Blue tape
Buffer	Blue tape or '20' spray painted on tree (any colour)	Pink tape	Blue tape or '20' spray painted on tree (any colour)
Filter Strip	'10' spray painted on tree (any colour)	Orange tape	Orange tape or spray
Planned Road	Pink tape	Red tape	Pink tape
Habitat Tree	Red tape, or H spray painted on tree (any colour)	H spray painted on tree (any colour)	H spray painted on tree (any colour)
Seed Tree	Red tape or S spray painted on tree (any colour)	S spray painted on tree (any colour)	S spray painted on tree (any colour)
Thinning Outrow	Orange tape or not marked in field	Blue tape or not marked in field	Not marked in field
Planned Log Landing	Tape (any colour) or L spray painted on ground	Tape (any colour) or marked on coupe plan only and not in field	Marked on coupe plan only and not in field

Note 1: Boundaries using obvious topographic features or roads may not require taping, at the discretion of the VicForests representative.

Note 2: If habitat or seed trees are selected by the Contractor, then marking of individual trees is not required.

Note 3: Where habitat or seed trees selected by the VicForests representative are not to be marked in the field, this must be specified in the Forest Coupe Plan.

SCHEDULE 9 - Sawlog Timber Specifications

B, C and D Grade Sawlog Timber Specifications - All Areas other than East Gippsland FMA

Parameter		Specification		
Timber		B Grade	C Grade	D Grade
Minimum small end diameter under bark (cm)		35	30	30
Log diameter under bark (cm)				
25-29	Permitted number of defective quarters with no pipe defect	n/a	n/a	0
30-34		n/a	0	1
35-39		0	1	2
>=40		1	2	3
Minimum graded length (m)		2.7	2.7	2.7
Loose gum veins or pockets or shakes		up to ¼ diameter under bark	up to the diameter under bark	up to twice the diameter under bark
Tight gum veins greater than 3mm		up to 1 diameter under bark	up to 7 diameter under bark	up to 10 diameter under bark
Tight gum veins less than 3 mm		up to twice the diameter under bark	Unlimited	Unlimited
Stain *		Light stain * only	tolerated	Tolerated
Sloping grain		Maximum of 1 in 10	maximum of 1 in 8	maximum of 1 in 8

1. No timber may have a sweep or crook which is greater than one-fifth of the diameter under bark of that timber at the apex of the sweep or crook, measured from a straight edge inside the sweep or crook of at least 2.4 metres.
2. No timber may have a pipe defect which exceeds the permissible size for the relevant grade of timber set out in the Hardwood Timber Grading Card published by VicForests. For the purpose of this paragraph, a "defect" is a feature affecting other than the surface or sapwood of a timber which prevents sawn timber of any merchantable grade being recovered from some or all of a timber.

B, C and D Grade Sawlog Timber Specifications - East Gippsland FMA

Parameter		Specification		
Timber		B Grade	C Grade	D Grade
Minimum small end diameter under bark (cm)		35	30	30
Log diameter under bark (cm)				
N/A	Permitted number of defective quarters with no pipe defect	n/a	n/a	0
30-34		n/a	0	1
35-39		0	1	2
>=40		1	2	3
Minimum graded length (m)		2.7	2.7	2.7
Loose gum veins or pockets or shakes		up to ¼ diameter under bark	up to the diameter under bark	up to 1.5 times the diameter under bark
Tight gum veins greater than 3mm		up to 1 diameter under bark	up to 7 diameter under bark	up to 10 diameter under bark
Tight gum veins less than 3 mm		up to twice the diameter under bark	Unlimited	Unlimited
Stain *		Light stain * only	tolerated	Tolerated
Sloping grain		maximum of 1 in 10	maximum of 1 in 8	maximum of 1 in 8

* Stain means the colour of solid wood, unaffected by defects such as rot.

* Light stain means a stain from which appearance grade sawn timber can be recovered.

1. No timber may have a sweep or crook which is greater than one-fifth of the diameter under bark of that timber at the apex of the sweep or crook, measured from a straight edge inside the sweep or crook of at least 2.4 metres.
2. No timber may have a pipe defect which exceeds the permissible size for the relevant grade of timber set out in the Hardwood Timber Grading Card published by VicForests. For the purpose of this paragraph, a "defect" is a feature affecting other than the surface or sapwood of a timber which prevents sawn timber of any merchantable grade being recovered from some or all of a timber.

E Grade Sawlog Timber General Specifications

Parameter	Specification		
	E1 Grade	E2 Grade	E2 Grade
		All FMA's excluding East Gippsland FMA	East Gippsland FMA
Minimum small end diameter under bark (cm)	20 for Ash spp 25 for Mixed spp	40 for all species	40 for all species
Maximum small end diameter under bark (cm)	55 for all spp	Unlimited	Unlimited
Permitted number of defective quarters	4	Refer to the Log Grading Card	Refer to the Log Grading Card
Minimum clearwood length within one quarter over a 2.7 m length (m)	1.2	1.2	Unlimited
Minimum graded length (m)	2.7	2.7	2.7
Allowable pipe	None	Not to exceed the maximum allowable pipe for a D grade log	As per the East Gippsland FMA Hardwood Sawlog Grading Card
Loose gum veins or pockets or shakes	Up to 5 times the log diameter under bark	Up to 5 times the log diameter under bark	Up to 1.5 times the log diameter under bark
Tight gum veins greater than 3mm	Unlimited	Unlimited	Up to 10 times the log diameter under bark
Tight gum veins less than 3 mm	Unlimited	Unlimited	Unlimited
Stain *	Unlimited	Unlimited	Unlimited
Sloping grain	Maximum of 1 in 5	Maximum of 1 in 5	Maximum of 1 in 7

* Stain means the colour of solid wood, unaffected by defects such as rot.

1. No timber may have a sweep or crook which is greater than one-fifth of the diameter under bark of that timber at the apex of the sweep or crook, measured from a straight edge inside the sweep or crook of at least 2.4 metres.

Dormit E Grade Specifications

DESIRABLE SPECIES – DANDENONG				
Species Group	Species	Common Name	Product Code	
Ash Species	<i>E. delegatensis</i>	Alpine Ash	AS-E	
	<i>E. nitens</i>	Shining Gum	AS-E	
	<i>E. regnans</i>	Mountain Ash	AS-E	
Mixed Species	<i>E. sieberi</i>	Silvertop	MS-E	
DESIRABLE SPECIES – SWIFTS CREEK				
Species Group	Species	Common Name	Product Code	
Ash Species	<i>E. delegatensis</i>	Alpine Ash	AS-E	
	<i>E. nitens</i>	Shining Gum	AS-E	
	<i>E. regnans</i>	Mountain Ash	AS-E	
Mixed Species	<i>E. denticulata</i>	Errinundra Shining Gum	MS-E	
	<i>E. sieberi</i>	Silvertop	MS-E	
	<i>E. fastigata</i>	Cut-tail	MS-E	
	<i>E. viminalis</i>	Manna Gum	MS-E	
	<i>E. dalrympleana</i>	Mountain Gum	MS-E	
	<i>E. obliqua</i>	Messmate	MS-E	
	<i>E. baxteri</i>	Brown Stringybark	MS-E	
	<i>E. globedia</i>	White Stringybark	MS-E	
	<i>E. macrorhyncha</i>	Red Stringybark	MS-E	
DORMIT E GRADE SAWLOG SPECIFICATIONS				
Minimum SED	AS-E 20 cm MS-E 25 cm	Permitted number of defective quarters with no pipe defect	Log Diameter (cm)	No. of Defective Quarters
Maximum LED	80 cm (Dandenong) 85 cm (Swifts Creek)		20-24	0
Minimum Graded Length	3.6 m		25-29	1
Preferred Log Lengths	3.7 – 4.0 m		30+	4
	7.4 – 7.6 m	Tight Gum Veins > 3 mm	Up to five times diameter.	
	11.1 – 11.5 m	Tight Gum Veins < 3 mm	Unlimited	
	* Log Lengths between 4.0 and 6.2 m should be avoided	Stain	Unlimited	
Other	No Pipe Defect	Sloping Grain	Maximum 1 in 5	
	No Charcoal	Sweep: No timber may have sweep which is >1/5 of the diameter of that timber at the apex of the sweep measured for a straight edge inside the sweep of at least 2.4 m.		
	No Split Logs			
	All Logs trimmed flush.			

SCHEDULE 10 - Pulplog Timber Specifications

Pulplog Grade by Species and Size Class

VICFORESTS PULPLOG SPECIFICATIONS			
PULPLOG GRADE BY SPECIES AND SIZE CLASS			
Species Name	Size Class Diameter (cm)		
	0 - 40	40 - 60	60+
Mountain Ash (<i>E. regnans</i>)	AS-H	AS-H	AS-H
Alpine Ash (<i>E. delegatensis</i>)	AS-H	AS-H	AS-H
Shining Gum (<i>E. nitens</i>)	AS-H	AS-H	AS-H
Silver Wattle (<i>A. dealbata</i>)	AC-H	AC-H	AC-H
Black Wattle (<i>A. meunsi</i>)	AC-H	AC-H	AC-H
Blackwood (<i>A. melanoxylon</i>)	AC-H	AC-H	AC-H
Shining Gum (<i>E. denticulata</i>)	MS-H	MS-H	MS-H
Silvertop (<i>E. sieberi</i>)	MS-H	MS-M (EG FMA) MS-H	MS-M (EG FMA) MS-H
Cut tail (<i>E. fastigata</i>)	MS-H	MS-M (EG FMA) MS-H	MS-M (EG FMA) MS-H
Manna Gum (<i>E. viminalis</i>)	MS-H	MS-M (EG FMA) MS-H	MS-M (EG FMA) MS-H
Blue Gum (<i>E. globulus</i> ssp.)	MS-H	MS-M (EG FMA) MS-H	MS-M (EG FMA) MS-H
Mountain Gum (<i>E. dalywoodiana</i>)	MS-H	MS-M (EG FMA) MSH	MS-M (EG FMA) MSH
Narrow Leaf Peppermint (<i>E. radjata</i> / <i>E. crossincolensis</i>)	MS-H	MS-M	MS-L (EG FMA) # MS-M
Messmate (<i>E. obliqua</i>)	MS-H	MS-M	MS-L (EG FMA) # MS-M
Grey Gum / Monkey Gum (<i>E. cypellocarpa</i>)	MS-H	MS-M	MS-L (EG FMA) # MS-M
Brown Stringy (<i>E. baxteri</i>)	MS-H	MS-M	MS-L (EG FMA) # MS-M
River Peppermint (<i>E. elata</i>)	MS-H	MS-M	MS-M
Maidens Gum (<i>E. maidenii</i>)	MS-H	MS-M	MS-M
Gully Gum (<i>E. smithii</i>)	MS-H	MS-M	MS-M
Swamp Gum (<i>E. ovata</i>)	MS-H	MS-M	MS-M
Brittle Gum (<i>E. mannifera</i>)	MS-H	MS-M	MS-M
Candle Bark (<i>E. rubida</i>)	MS-H	MS-M	MS-M
Broad Leaf Peppermint (<i>E. dives</i>)	MS-H	MS-M	MS-M
Yellow Stringy (<i>E. muelleriana</i>)	MS-H	MS-M	MS-L #
White Stringy (<i>E. globoides</i>)	MS-H	MS-M	MS-L #
Mahogany (<i>E. botryoides</i> / <i>E. robusta</i>)	MS-H	MS-M	N/A
Apple-topped Box (<i>E. angophoroides</i>)	MS-H	MS-M	N/A
Blue Leaf Stringy (<i>E. agglomerata</i>)	MS-H	MS-M	N/A
Red Stringy (<i>E. macronyncha</i>)	MS-H	MS-M	N/A
Ironbark (<i>E. tricarpa</i>)	N/A	N/A	N/A
Woollybutt (<i>E. longifolia</i>)	N/A	N/A	N/A
Greybox, Redbox (<i>E. bosistoana</i> , <i>E. polyanthemos</i>)	N/A	N/A	N/A
Yertchuk (<i>E. consideriana</i>)	N/A	N/A	N/A
Bloodwood (<i>C. gummifera</i>)	N/A	N/A	N/A

^ EG FMA - East Gippsland Forest Management Area

EG FMA Measure is determined as a function of stump diameter over bark

General Pulplog Specifications

Parameter	Specification
Minimum small end diameter (SED*) under bark	8 cm for both round and split logs
Maximum large end diameter (LED*) under bark	60 cm*
Minimum length	3.0 metres****
Maximum length	12.0 metres
Size Class Diameter	As a measure of DBHOB
Branches	Less than half log diameter and flush trimmed
Charcoal	100 % free
Bark	100 % free
Sweep	Less than diameter over 2.4 metres and to the extent that the effective diameter, including sweep, does not exceed 60 cm*
Spiral Grain	Less than half diameter over 2.4 meters
Shattered ends and slovens	Removed
Split logs	Acceptable and clean of all rot and mud

* Note that the SED and LED specifications may be varied by agreement for specific buyers.

** Note that maximum length specifications may be varied for specific buyers or truck configurations to maximise haul options

*** Note that the maximum and minimum diameter specifications may be varied for specific buyers depending on chipper configuration and size.

**** Note that the minimum length may be varied for specific harvest and haul configurations.

Pulplog Defect Tolerances

Size Class	Permitted Defect
Logs and slabs less than 40 cm diameter	Defect not to exceed 50% of diameter
	Minimum wood depth of 10 cm across the diameter of the log
Logs and Slabs between 40 and 60 cm large end diameter (LED)	Logs must have an average of 10 cm of solid wood between the pipe and outside diameter of the log, for the length of the log
Logs with a pipe of greater than 25 cm	If rot or mud present then must be split with all rot and mud removed.
Logs greater than LED cm	Must be split to render maximum piece size less than 60cm

Firewood General Specifications

Parameter	(a) Specification
Minimum small end diameter under bark	10 cm
Maximum large end diameter under bark	Logs over 80 cm must be split
Minimum number of defective quarters	4
Pipe defect	A minimum depth of 10 cm of solid wood, measured from the pipe to the outside of the log
Minimum log length	2.7 m
Maximum log length	13 m or less
Loose gum veins, pockets or shakes	Unlimited
Tight gum veins greater than 3 mm	Unlimited
Tight gum veins less than 3 mm	Unlimited
Stain	Unlimited
Sloping grain	1 : 8
Sweep	No pronounced bends or sharp sweep
Species	As per Schedule 11

General Poles, Piles and Posts Specifications

Parameter	Specification
Minimum small end diameter under bark	15 cm
Maximum large end diameter under bark	40 cm
Number of defective quarters	Up to 4
Green limbs	Up to 20% of log circumference – trimmed flush
Pipe defect	Not permitted
Log length	12 m
Stain and Gum vein	Acceptable
Spiral Grain	Not Permitted
Sweep	No pronounced bends or sharp sweep
Species	Eucalypt species as per Schedule 11

SCHEDULE 11

Species Codes

The following species codes are acceptable on log docket:

Species ID	Genus	Species	Common Name
AA	Eucalyptus	delegatensis	Alpine Ash
AC	Acacia	- not specified -	Acacia species
AM	Eucalyptus	All	Ash and Mixed Species
AS	Eucalyptus	All ash	Mixed ash species
BD	Corymbria	gummifera	Red Bloodwood
BG	Eucalyptus	bicostata / pseudoglobulus / maidenii / globulus	Mixed Blue Gum Species
BO	Elaeocarpus	holpetalus	Black Olive Berry
BS	Eucalyptus	baxteri	Brown Stringybark
BW	Acacia	melanoxydon	Blackwood
BX	Eucalyptus	- not specified -	Box Species
CB	Eucalyptus	rubida	Candlebark
CT	Eucalyptus	fastigata	Cut-tail
CU	Exocarpus	cupressiformis	Cherry Ballart
CY	Eucalyptus	cypellocarpa	Mountain Grey Gum
DA	Eucalyptus	dalrympleana	Mountain Gum
DE	Eucalyptus	denticulata	Errinundra Shining Gum
GG	Eucalyptus	bosistoana	Gippsland Grey Box
IB	Eucalyptus	tricarpa	Red Ironbark
MA	Eucalyptus	regnans	Mountain Ash
MM	Eucalyptus	obliqua	Messmate
MS	Eucalyptus	Mixed	Non-ash mixed species
PM	Eucalyptus	dives / croajingolensis / radiata / robertsonii / nitida / willisii	Peppermint
RB	Eucalyptus	polyanthemus	Red Box
RP	Eucalyptus	elata	River Peppermint
RS	Eucalyptus	macrorhyncha	Red Stringybark
SA	Atherosperma	moschatum	Sassafrass
SG	Eucalyptus	nitens	Shining Gum
SM	Eucalyptus	botryoides	Southern Mahogany
SP	Minor	- not specified -	Any Genus not specified
ST	Eucalyptus	sieberi	Silvertop
SW	Acacia	dealbata	Siver Wattle
VM	Eucalyptus	viminalis	Manna Gum
WS	Eucalyptus	globoidea	White Stringybark
YK	Eucalyptus	consideniana	Yertchuk
YS	Eucalyptus	muelleriana	Yellow Stringybark

Firewood Species Codes

Ash Species Firewood	AS
Botanical name	Common name
<i>Eucalyptus delegatensis</i>	Alpine Ash
<i>Eucalyptus nitens</i>	Shining Gum
<i>Eucalyptus regnans</i>	Mountain Ash
Mixed Species Firewood	MS
<i>Eucalyptus agglomerata</i>	Blue Stringybark
<i>Eucalyptus baxteri</i>	Brown Stringybark
<i>Eucalyptus bicostata</i>	Blue Gum
<i>Eucalyptus botryoides</i>	Southern Mahogany
<i>Eucalyptus bridgesiana</i>	Apple Box
<i>Eucalyptus consideriana</i>	Yertchuk
<i>Eucalyptus croajingolensis</i>	Gippsland Peppermint
<i>Eucalyptus cypellocarpa</i>	Mountain Grey Gum
<i>Eucalyptus dalrympleana</i>	Mountain Gum
<i>Eucalyptus denticulata</i>	Errinundra Shining Gum
<i>Eucalyptus dives</i>	Broad-leaved Peppermint
<i>Eucalyptus elata</i>	River Peppermint
<i>Eucalyptus fastigata</i>	Cuttail
<i>Eucalyptus globoidea</i>	White Stringybark
<i>Eucalyptus macrorhyncha</i>	Red Stringybark
<i>Eucalyptus mannifera</i>	Brittle Gum
<i>Eucalyptus muelleriana</i>	Yellow Stringybark
<i>Eucalyptus obliqua</i>	Messmate
<i>Eucalyptus pseudoglobulus</i>	Gippsland Blue Gum
<i>Eucalyptus radiata</i>	Narrow-leaved Peppermint
<i>Eucalyptus rubida</i>	Candlebark Gum
<i>Eucalyptus sieberi</i>	Silvertop
<i>Eucalyptus smithii</i>	Gully Gum
<i>Eucalyptus viminalis</i>	Manna Gum
<i>Eucalyptus tricarpa/ sideroxylon</i>	Red Ironbark
<i>Eucalyptus polyanthemus</i>	Red Box
<i>Eucalyptus bosistoana</i>	Gippsland Grey Box
<i>Eucalyptus gonicalyx</i>	Long leaf box

SCHEDULE 12

Grade Codes

The following grade codes are acceptable on log docket:

Grade Code	Grade Name
Sawlog	
B	B grade sawlogs
C	C grade sawlogs
D	D grade sawlogs
E	E1 grade sawlogs
	E2 grade sawlogs
U	Ungraded sawlog
Residual	
H	High Quality (pulp)
M	Medium Quality (pulp)
Firewood	
F	Dry (firewood)
G	Green (firewood)
Other Products	
P	Poles/Piles/Posts

From time to time customer specific specification for the above product codes may apply as specified by the VicForests representative.

Mixed Species Sawlog Species Sub-Groups

The following species group codes are used where mixed species logs are sold in specified groups of species.

M1	M2	M3	M4	M5*	M6	MS
Messmate	Grey gum	Manna Gum	Any mixed Species: undefined proportions	Yellow Stringybark	All Stringybark species	Any mixed species: run of bush
Silvertop	Stringybarks	Shining Gum (<i>E.denticulata</i>)		Southern Mahogany	Mountain Grey Gum	
Cut-tail	Peppermints			Ironbark	Blue Gum	
	Other Species			Box Species	Box Species	
				Blue Gum	Red Iron Bark	
					Southern Mahogany	

***M5 Species will generally not be included in other sub-groups in East Gippsland FMA, and may be specified as individual species in sales contracts and timber lots.**

SCHEDULE 13

Hardwood Log Grading Card

